

TRANSFLUID

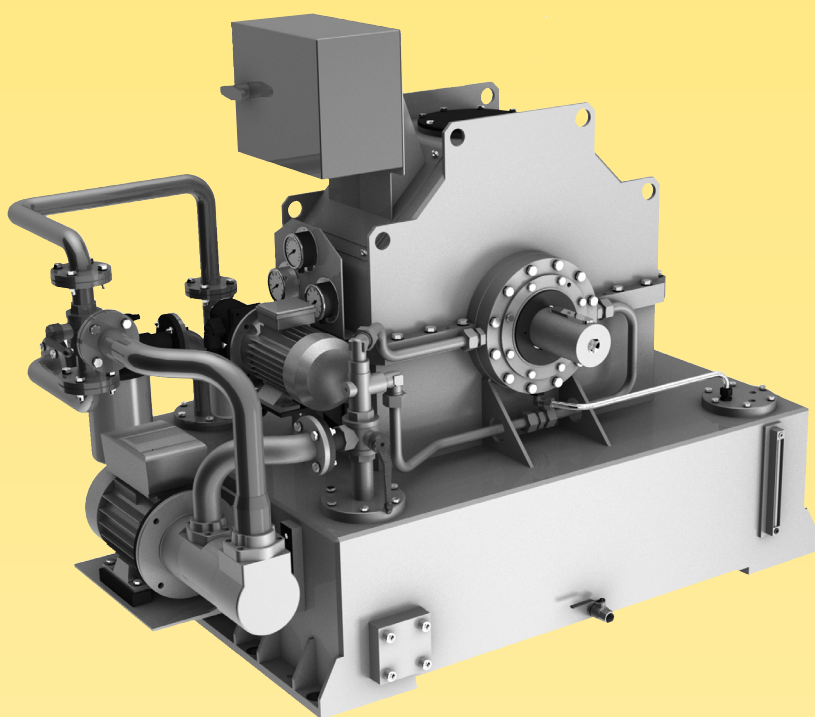

TRANSFLUID

trasmissioni industriali



drive with us

KSL
VARIABLE FILL FLUID COUPLINGS

INTRODUCTION

INTRODUCTION

Transfluid designed the **KSL** series variable fill fluid coupling to overcome difficulties experienced during 'start up' and 'speed variation' operation for medium or high powered machines, driven by electric motors or internal combustion engines.

WORKING OPERATION

Extremely efficient performance is achieved utilizing the KSL's very simple and effective principle. Oil, as the power medium, is pumped from a sump to the hydrodynamic coupling circuit, where it is finally 'drained-off' through a series of orifice plugs, back into the sump.

The variable fill principle:

By controlling the oil flow to the working circuit through a frequency converter, changes occur inside the coupling's working circuit which alter the coupling's slip characteristics dramatically softening the 'start up'.

Torque limiting function:

Having all the same advantages of fluid couplings, variable fill-drain type fluid couplings build up torque gradually.

Disconnect:

Interrupting the oil flow into the coupling empties the working circuit and disconnects the input from the output.

This disconnection can be accelerated by using the quick release valves.

In summary, it is possible to:

- have a long start up acceleration, up to several minutes, for high inertia machines.
- position the driven machine for loading, unloading and maintenance.
- obtain sequential starting for more than one drive motor.
- adjust or limit the torque
- disconnect the load even with the motor running
- use for conveyors, for the reduction of the tension to a minimum level or the possibility of running at an inspection speed.
- vary the speed within a 5:1 range for centrifugal machines.

CHARACTERISTICS

Soft starter

The KSL working circuit is gradually filled by oil from an empty condition to a fully filled one. Such behaviour provides an extremely soft controlled start up, especially with high inertia machinery. The KSL variable oil feed system is controlled by a frequency converter during the ramp up, producing ideal soft starting.

Accurate speed variation

By remote signal, the KSL always guarantees output speed accuracy, as required by the operator or control system.

Speed variation is also possible by manual flow control valve operation.

A frequency converter electronic bypass is supplied standard.

Vibration Dampening

One of the most important characteristics of KSL fluid coupling is its torsional vibration dampening effect, protecting both the driven gear box, fan, or pump machinery, as well as the motor or engine.

Overload Protection

This is a fluid coupling advantage and a big benefit to users. Even more protection can be achieved by installing "quick release valves" which discharge oil from the working circuit in few seconds, limiting prolonged overloads completely.

High Efficiency

The KSL is an extremely efficient device compared to the constant filled type fluid coupling, because the working circuit volume is controlled at the fullest possible level to maintain a very small slip rate.

Shaft Labyrinth Sealing

This type of seal helps the KSL series to be a low maintenance machine.

Ease of Maintenance

Thanks to its split casing design, it is possible to remove the complete fluid coupling impeller assembly without having to move either the motor/engine or driven machinery, saving the need for realignment and costly down time.

Optional

Auxiliary Lubrication unit for prime mover and/or driven machine bearing.

ATEX EEx

Upon request.

APPLICATIONS

Mills, crushers, conveyors, fans, blowers, pumps, compressors, centrifuges, mixers, generators, marine propulsion drives.

SELECTION

To correctly select the KSL, Transfluid needs to know the following data:

- motor/engine type, power and speed
- driven machinery type, power, speed and inertia
- output speed range
- environmental conditions
- cooling water/air characteristics
- drive and driven shaft dimensions and tolerances
- available voltage for motors and instruments

AUTOMATIC

or **SEMIAUTOMATIC / MANUAL**

or **MANUAL**

All parameters under control such as:
speed, start up modulation, oil pressure,
oil temperature, filter clogging, oil level,
heat exchanger pump thermostatic control.

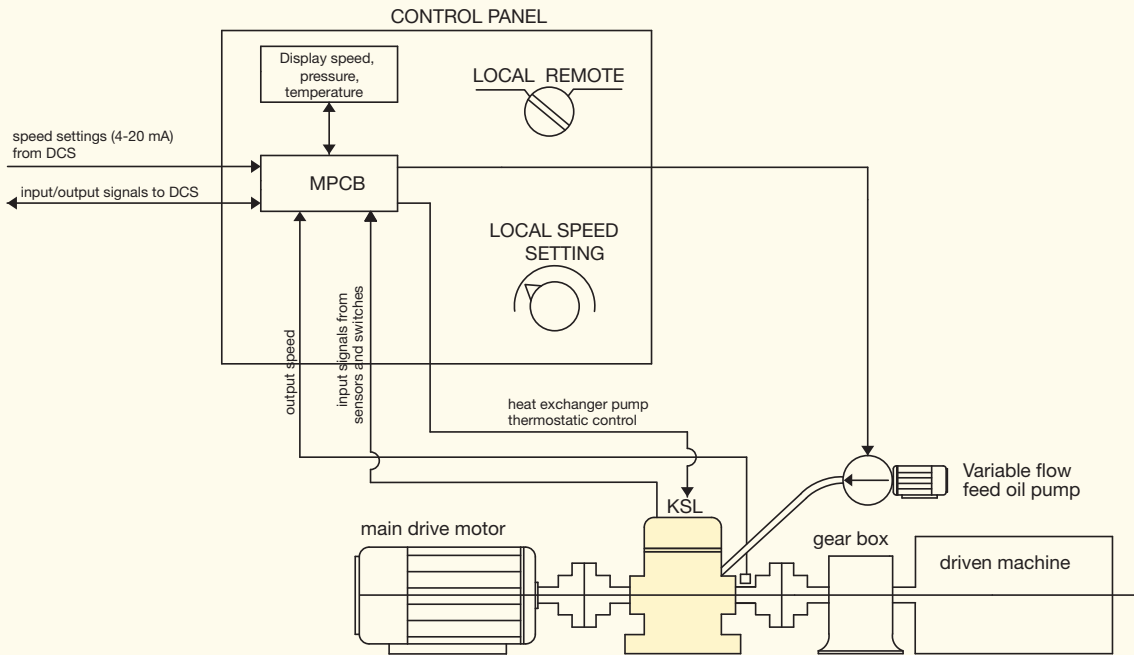

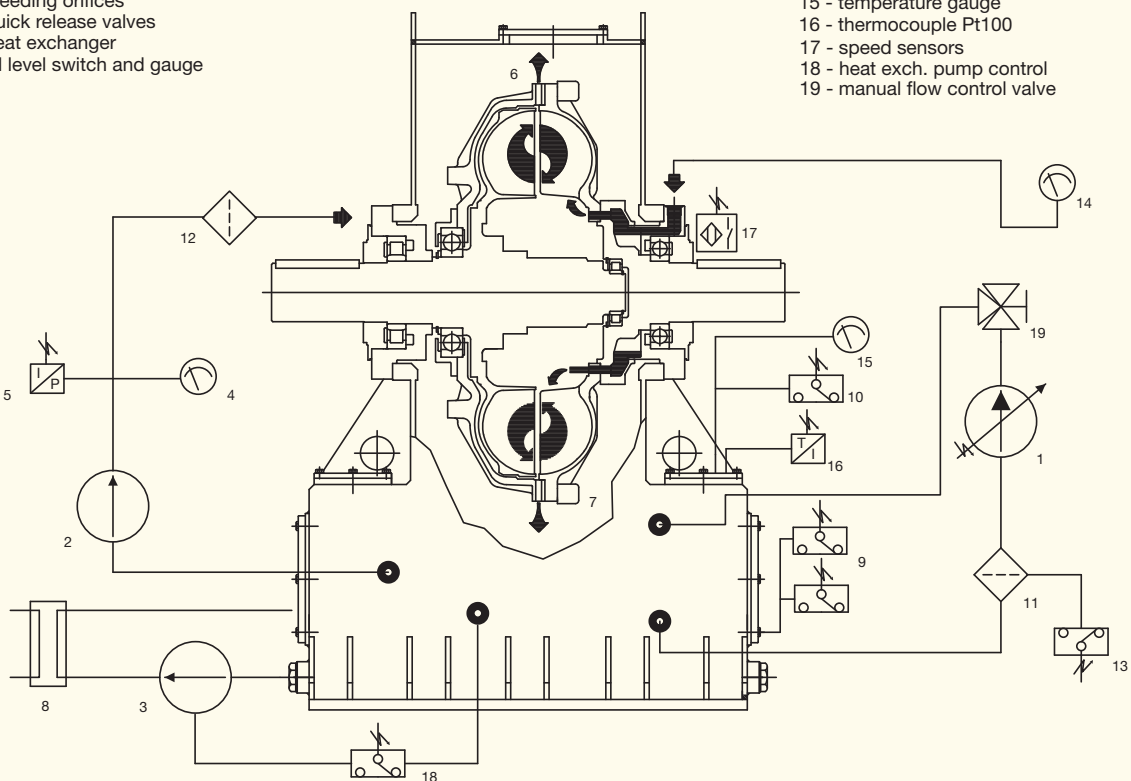

- 1 - variable flow feed pump with variable frequency converter
- 2 - lubrication oil pump
- 3 - heat exchanger oil pump
- 4 - pressure gauge
- 5 - pressure differential transducer
- 6 - bleeding orifices
- 7 - quick release valves
- 8 - heat exchanger
- 9 - oil level switch and gauge

- 10 - max temperature switch
- 11 - feed oil filter
- 12 - lub. oil filter
- 13 - vacuum switch
- 14 - pressure gauge
- 15 - temperature gauge
- 16 - thermocouple Pt100
- 17 - speed sensors
- 18 - heat exch. pump control
- 19 - manual flow control valve



PERFORMANCES

MOTOR POWER - kW

 n_1, n_2  Size / Kw max

	21 HS	24 HS	27	29	34	D34	46	D46
1000	-	-	200	360	750	1300	1800	3500
1200			360	630	1300	2300	3000	4000
1500			700	1250	2000	2800		
1800			1200	1600	2400*	3350*		
3000	1600*	2600*						
3600	2000*	3200*						

* With steel impellers.

NOTE: Standard squirrel cage motors should NOT be derated.
 Efficiency of electric motor is NOT affected by KSL application.
 Value of electric motor efficiency can be found in manufacturer's catalogue.
 Slip can vary $\pm 10\%$ according to driven machine characteristics.

CENTRIFUGAL APPLICATION

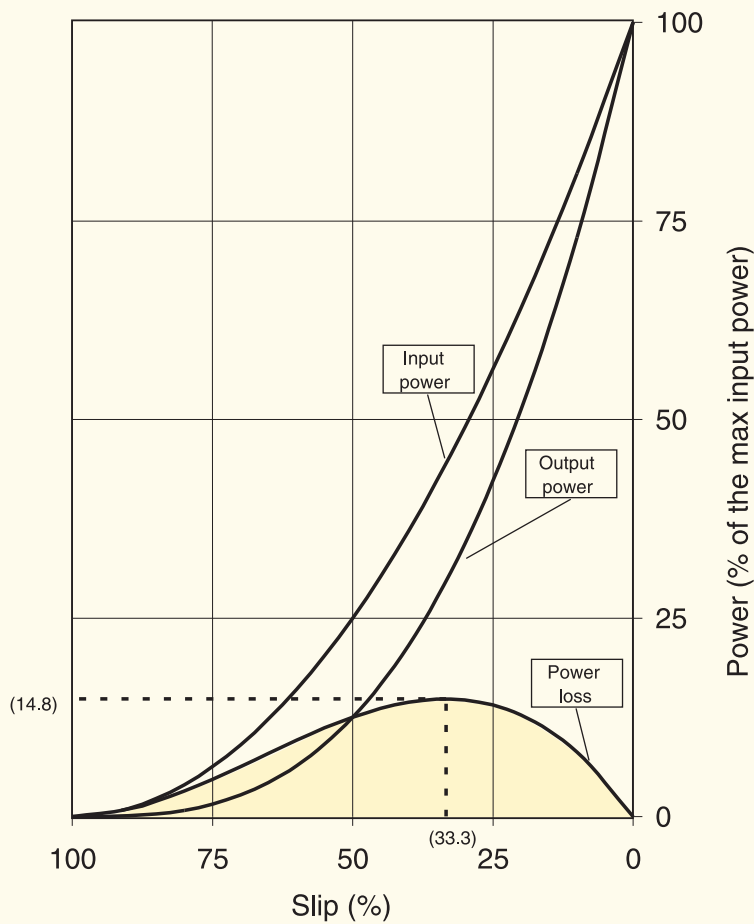

LOSSES %	OUTPUT SPEED %
0	100
8.1	90
12.8	80
14.8	70
14.4	60
12.5	50
9.6	40
6.3	30
3.2	20

average value = 9.6

$$\text{input} = K n_2^3 + K (n_1 - n_2) n_2^2$$

$$\text{output} = K n_2^3$$

$$\text{losses} = K (n_1 - n_2) n_2^2$$

$$K = \text{max input power} / n_1^3$$

$$n_1 = \text{input speed}$$

$$n_2 = \text{output speed}$$

BOILER FEED WATER PUMPS, PIPE LINE PUMPS, CENTRIFUGAL GAS COMPRESSORS, CITY FEED WATER PUMPS, RECYCLING PUMPS, ALL FANS AND BLOWERS

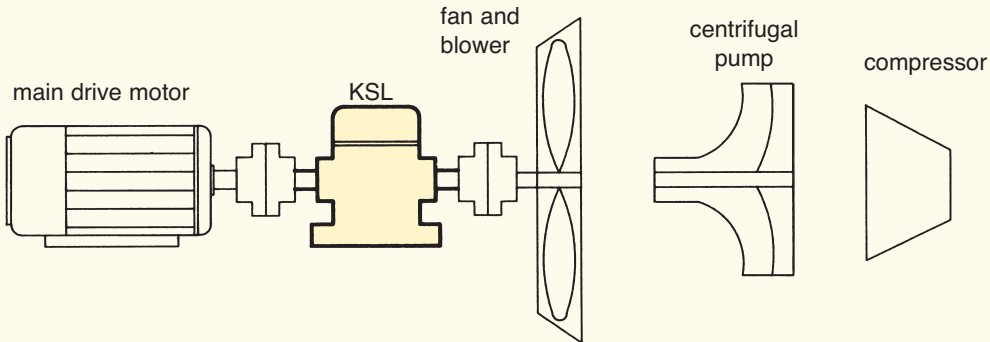

HAMMER MILLS, BALL MILLS, STONE CRUSHERS, METAL SHREDDERS, WOOD CHIPPERS

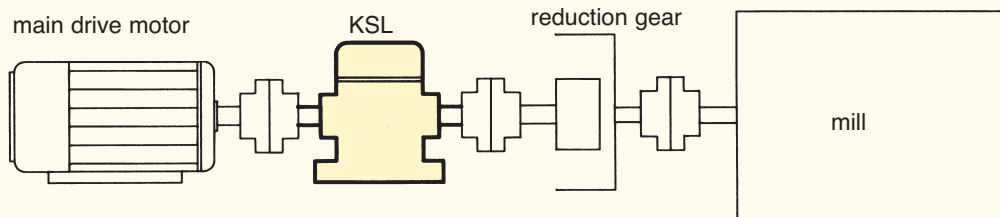

ELECTRICITY CONTINUITY GROUPS

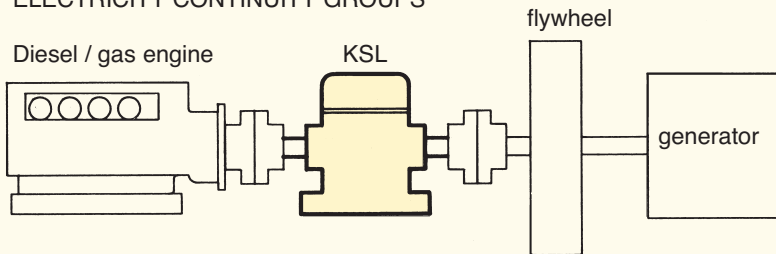

GAS TURBINE STARTING DRIVES

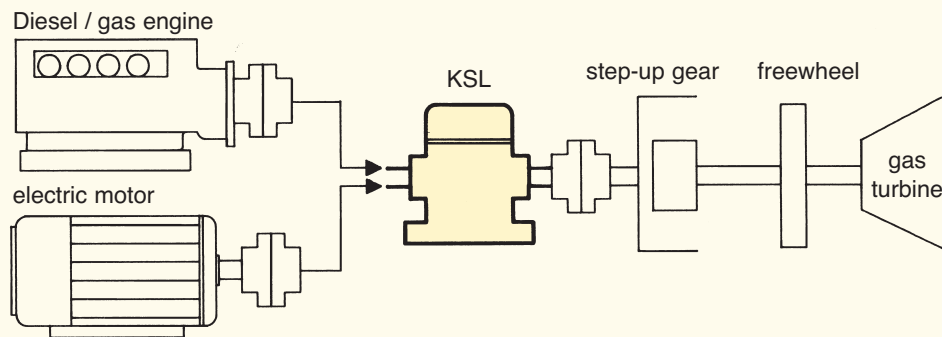

BELT CONVEYORS

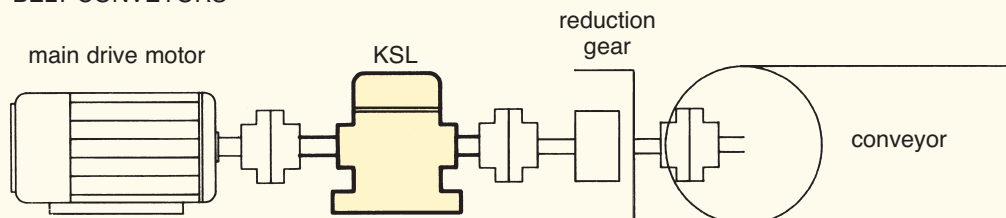

DIMENSIONS

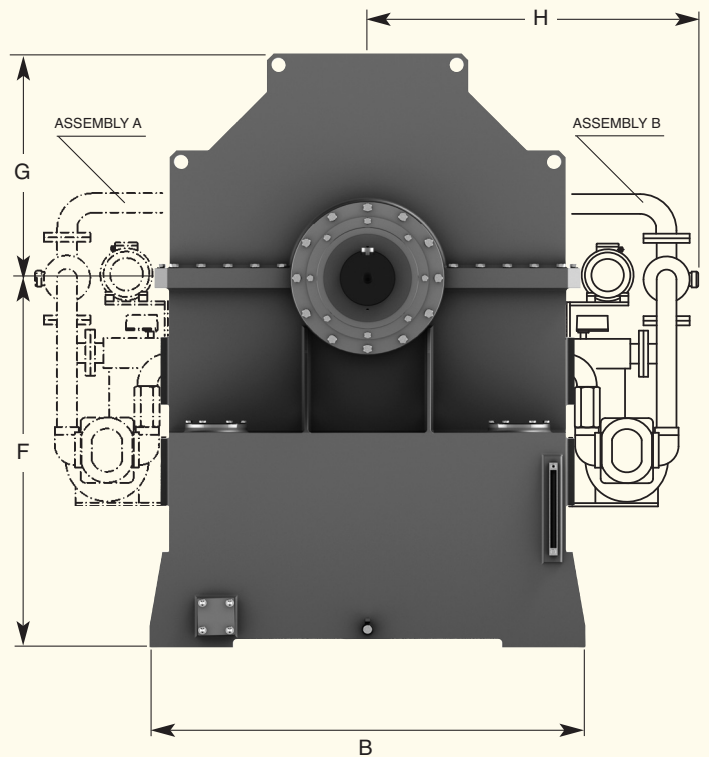
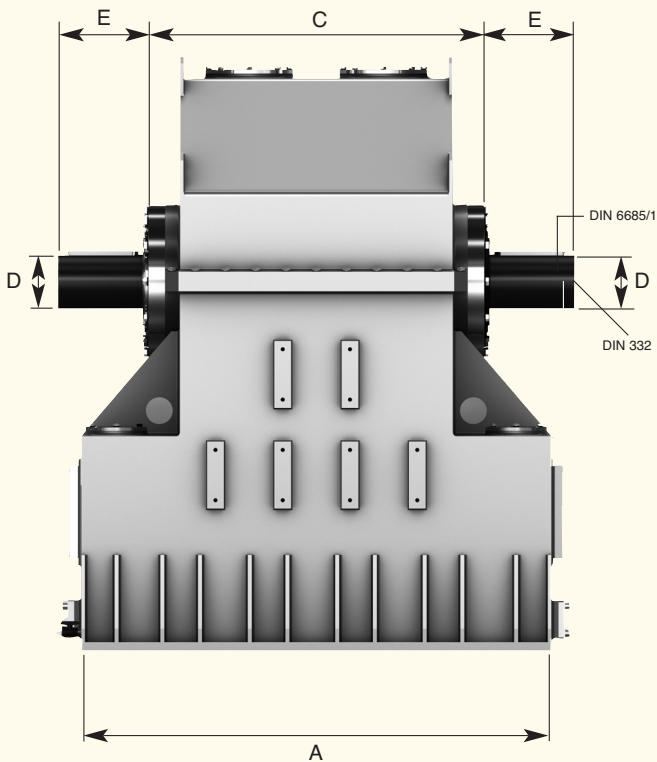

Dimensions (mm)

Size	A	B	C	D	E	F	G	H	Weight Kg (without oil)	Oil lt
21 HS	940	1500	580	100	170	700	490	1150	1100	400
24 HS	1300	1500	580	100	170	725	490	1150	1500	600
27 / 29	900	1100	660	120	170	850	550	1000	1200 / 1300	300
34	1050	1300	790	140	220	1000	670	1050	2100	450
D34	1400	1300	1040	160	250	1100	670	1050	3000	850
46	1420	1700	1060	180	270	1300	900	1200	3455	1000
D46	1800	1700	1400	200	300	1300	900	1200	4100	1300

WEIGHT ACCORDING TO STANDARD VERSIONS
DIMENSIONS ARE SUBJECT TO ALTERATION WITHOUT NOTICE

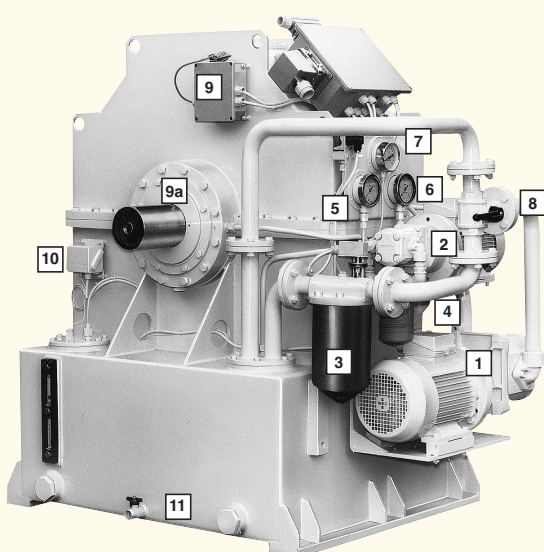

- 1 Variable flow pump
- 2 Lubrication oil pump
- 3 Feed filter with vacuum switch
- 4 Lube filter with differential pressure transducer
- 5 Feed pressure gauge
- 6 Lube pressure gauge
- 7 Temperature gauge
- 8 Filter by-pass valve
- 9 Speed controller box
- 9a Proximity switch
- 10 Temperature switch
- 11 Drain tap

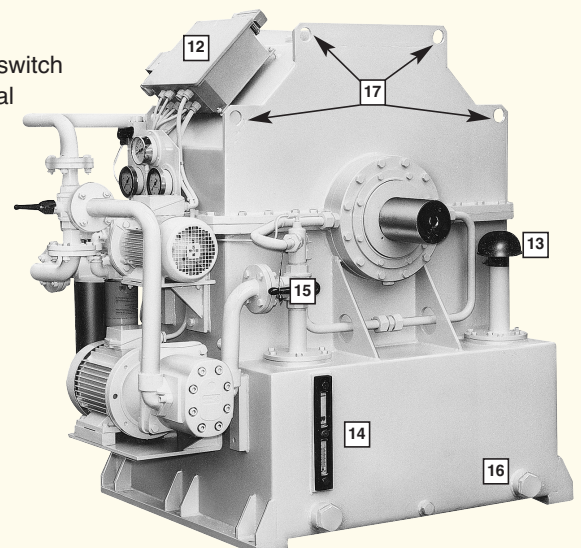

- 12 Electric wiring box
- 13 Breather
- 14 Level switch and gauge
- 15 Manual control valve
- 16 Cooler pipe unions
- 17 Lifting ears

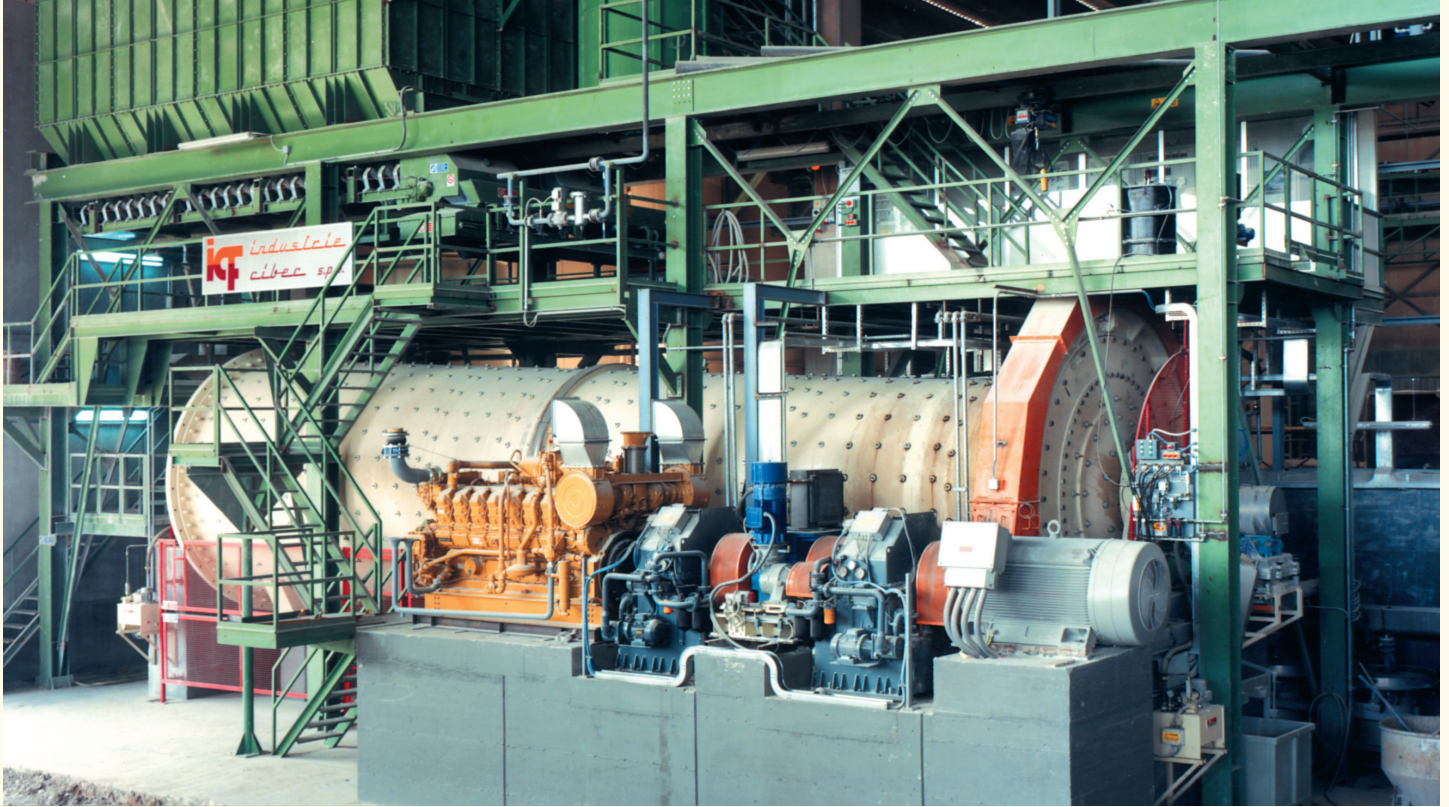

2x34 KSL, 630 kW - 1000 rpm, Ceramic mill (Italy)



34 KSL, 700 kW - 1200 rpm, Fan (Brasil)

Tables for the preliminary selection of the coolers:

- KSL with oil cooler motor pump (2 poles motor)
- Refer to available speed drive or start up drive column
- Max power = max power at max speed
- Output water temperature 35°C
- For power higher than those listed below, please apply Transfluid

VARIABLE SPEED APPLICATION				
Fluid Coupling max. power (kW)	Water-Oil Cooler Model	Required Water Flow (l/min) at 25°C	Cooler Oil Pump Model	Air-Oil Cooler Model (air = 30 °C)
700	08084 • SP3-31 ••	220	GR55SMT250L	GATF5940CE GATF5940CF
800	08120 • SP3-41 ••	251	GR55SMT300L	GATF5940CE GATF5940CF
900	08120 • SP3-41 ••	282	GR55SMT380L	GATF5940CE GATF5940CF
1000	08120 • SP3-41 ••	314	GR55SMT380L	2xGATF5940CA 2xGATF5940CB
1200	10098 • SP3-51 ••	377	GR60SMT440L	2xGATF5940CA 2xGATF5940CB
1400	12078 • SP3-71 ••	440	GR60SMT500L	3xGATF5940CE 3xGATF5940CF
1600	12078 • SP3-71 ••	502	GR70SMT600L	3xGATF5940CE 3xGATF5940CF
1800	12098 •	565	GR70SMT800L	3xGATF5940CE 3xGATF5940CF
2000	12098 •	628	GR70SMT800L	3xGATF5940CE 3xGATF5940CF

START-UP APPLICATION				
Fluid Coupling max. power (kW)	Water-Oil Cooler Model	Required Water Flow (l/min) at 25°C	Cooler Oil Pump Model	Air-Oil Cooler Model (air = 30 °C)
700	06060 • SP3-11 ••	55	GR40SMT100L	GATF5940CY
800	06060 • SP3-11 ••	62	GR40SMT100L	GATF5940CY
900	06060 • SP3-11 ••	70	GR40SMT100L	GATF5940CZ
1000	06060 • SP3-11 ••	78	GR40SMT100L	GATF5940CZ GATF5940DA
1200	06060 • SP3-11 ••	94	GR40SMT150L	GATF5940DA
1400	06096 • SP3-19 ••	110	GR40SMT150L	2xGATF5940CA 2xGATF5940CB
1600	06096 • SP3-31 ••	125	GR40SMT150L	2xGATF5940CA 2xGATF5940CB
1800	08084 • SP3-31 ••	141	GR45SMT180L	2xGATF5940CA 2xGATF5940CB 3xGATF5940CE
2000	08084 • SP3-31 ••	157	GR45SMT180L	2xGATF5940CA 2xGATF5940CB 3xGATF5940CE

• Tube bundle heat exchanger

•• Plate heat exchanger

Before ordering, ask Transfluid for a dedicated check of the heat exchanger

AUSTRALIA

TRANSFLUID AUSTRALIA PTY LTD
Smithfield NSW 2164
Tel.: +61 297572655
Fax: +61 297560181
tfaustralia@transfluid.it

CHINA

TRANSFLUID BEIJING TRADE CO. LTD
Beijing
Tel.: +86.60442301-2
Fax: +86.60442305
tbtcinfo@sina.com

RUSSIAN FEDERATION

TRANSFLUID OOO
Moscow
Tel.: +7.495.7782042
Mob.: +7.926.8167357
tfrussia@transfluid.it

BRAZIL

TRANSFLUID DO BRASIL
Representative Office
05014-060 Sao Paulo SP
Tel.: +55.11.48235308
Fax: +55.11.48235308
tfbrasil@transfluid.it

FRANCE

TRANSFLUID FRANCE s.a.r.l.
38500 Voiron
Tel.: +33.9.75635310
Fax: +33.4.26007959
tfrance@transfluid.it

U.S.A. & CANADA

TRANSFLUID LLC
Auburn, GA30011
Tel.: +1.770.8221777
Fax: +1.770.8221774
tfusa@transfluid.it

LOCAL DISTRIBUTOR

Global web site: www.transfluid.eu
E-commerce web site: www.buy-transfluid.com