

TRANSFLUID

trasmissioni industriali

ITALY

TRANSFLUID SRL
Via Guido Rossa, 4
21013 Gallarate (VA)
Tel. +39.0331.28421
Fax +39.0331.2842911
info@transfluid.it

AUSTRALIA

TRANSFLUID AUSTRALIA PTY LTD
Smithfield NSW 2164
Tel. +61.297572655
Mob. +61.297560181
tfaustralia@transfluid.it

CHINA

TRANSFLUID BEIJING TRADE CO.LTD
Beijing
Tel. +86.60442301-2
Fax +86.60442305
tbtinfo@sina.com

FRANCE

TRANSFLUID FRANCE s.a.r.l.
38500 Voiron
Tel. +33.9.75635310
Fax +33.4.26007959
tffrance@transfluid.it

RUSSIAN FEDERATION

TRANSFLUID OOO
Moscow
Tel. +7.495.7782042
Mob. +7.926.8167357
tfrussia@transfluid.it

U.S.A. & CANADA

TRANSFLUID LLC
Auburn, GA 30011
Tel. +1.770.822.1777
Fax +1.770.822.1774
tfusa@transfluid.it

www.transfluid.eu
www.buy-transfluid.eu

drive with us

January 2014



Transfluid

Founded in Milan Italy in 1957, Transfluid has always been a point of reference in the world of industrial transmission equipment and the standard that its competitors measure themselves.

Fluid couplings, variable speed drives, brakes, clutches, couplings and hydraulic transmissions constitute the core of the product line, while ultra-modern technology, careful selection of materials and meticulous assembly are the key ingredients in the recipe that has placed those products at the forefront of the market.

Thousands of customers continue to choose Transfluid for the most diverse and demanding applications, knowing they can rely on Transfluid's technical department, where design, engineering and planning experts are always on hand to quickly resolve client's problems.

Italian dynamic innovation, coupled with ongoing staff development and more than fifty years of hard-earned expertise, are the foundation of the company's success.

Transfluid's unique approach has sparked small but important revolutions in the field of heavy-duty transmissions, for which recognition has come in the form of international awards.

Transfluid's catalogue boasts a wide range of products, and each unit produced is tested for safety, quality and durability. Being a world leader in the design and manufacture of fluid couplings, Transfluid has earned a reputation for diligent service, which assures the competence of the applications through careful quality control and on-site technical assistance.

In addition to the Italian Headquarter, Transfluid's broad sales network consists of five branches located in Australia, China, France, Russia and United States, one representative office in Brazil and 42 distributors located throughout the world.

The speed variation

To meet the energy savings and reliability demands modern industry expects, Transfluid has developed two new lines of variable, high-speed hydraulic couplings, the KSL-HS and the KPTB-HS. Capable of input speeds of 3600RPM the HS family of couplings has already found demands in the power, steel, paper, cement, chemical and petrochemical industries. The high-speed products are finding applications in boiler feed pumps, fans, blowers, pumps, compressors.

With more than half a century of experience in the field of variable speed drives, Transfluid is using its expertise to expand into the high-speed markets with the KSL-HS and KPTB-HS series of variable high-speed drives.

How it works

In centrifugal machines, such as pumps, compressors and fans, the speed control plays a crucial role in saving energy. As an example, by decreasing the driving speed of a centrifugal machine to 50% of its normal operating speed, the current draw of the driving electric motors is reduced to one eighth of its normal draw.

Therefore, in application or processes that do not require the centrifugal machine maximum output, the benefit of a variable speed drive is easily realized through significant power savings. This important variable speed function can be accomplished by installing a variable fill hydrodynamic coupling in the drive train. By controlling the volume of oil that circulates inside a variable speed coupling the output speed can be continuously changed to optimize the driven machines performance. Traditionally controlling the oil volume is accomplished via scoop tube, however, Transfluid has pioneered a solution based upon the most current technology called flow control.

The flow control variable speed hydrodynamic coupling is based on a very simple principle. The power media (oil) is withdrawn from the tank by an electric feed pump and fed to the driving and driven impellers of the coupling circuit. The oil is removed by centrifugal force through calibrated orifices on the perimeter of the circuit. The oil then returns to the tank by gravity. By varying the feed pump oil flow, the volume of oil between the driving and driven impellers can be changed. The end result is accurate control of driven machines acceleration time and precise speed variation. Simple operation, standard and externally accessible maintenance components, make the KSL-HS and KPTB-HS a simple, reliable, low maintenance, variable speed solution.

Benefits

It is well known that speed control of centrifugal machines provides significant economic advantages compared to the use of valves or dampers. In applications that require a broad speed range, valves and dampers drastically reduce the overall efficiency of the system.

The features of KSL-HS and KPTB-HS high-speed couplings combine a simple design with the high efficiency of a hydraulic coupling to provide an optimal solution for centrifugal machine design.

Among existing variable speed technologies the two most common are the Frequency Inverter and the Hydrodynamic Couplings. Although inverter technology has made some significant advances, the Hydrodynamic Coupling offers key advantages that cannot be replaced by any other technology.

- A variable speed hydrodynamic coupling allows a motor to be powered directly from the main electrical circuit and operate at its nominal speed. This allows for the use of standard motors that are more economical to purchase than those designed for use with variable frequency drives.

- The important difference is that an inverter driveline is a permanent mechanical connection between the motor and the driven machine. A hydrodynamic coupling eliminates this connection allowing torque to be transmitted without damaging other mechanical parts from torque spikes and torsional vibrations. This extends the overall operational life of the entire driveline.

- Hydrodynamic couplings are robust and reliable machines. Service can be done by a qualified mechanic. In contrast, the maintenance of a frequency inverter is expensive due to the rapid and random failure of its components and its rapid obsolescence

of parts. Additionally, inverter repair requires highly skilled, specialized, technicians and extended service times.

- A hydrodynamic coupling is installed in the driveline, while a frequency inverter requires a dedicated pressurized and air conditioned room.

- Hydrodynamic Couplings are less expensive than inverters. Additionally inverters require special motors and at times the selection of higher rated motors.

TRANSFLUID HS couplings also offer advantages compared to the traditional scoop tube system. The scoop tube is a stationary element that is an obstacle to the oil in rotation, inducing a significant hydrodynamic resistance and decreased efficiency.

A closed loop "feedback" is required to control the linear position of the scoop as it relates to the output speed. When ordering, application rotation direction must be specified.

Furthermore, major components such as the scoop and oil pump are integrated inside the coupling housing making repairs difficult and time consuming.

The TRANSFLUID control flow system:

- is self-adjusting, since the draining of oil from the calibrated orifices depends on the rotation speed of the outer impeller which is directly connected to the driven machine. This allows the coupling to stabilize its speed in the presence of load variations without the need for corrective actions and "loop" control
- eliminates the stationary element (the scoop) and hydrodynamic resistance in the working circuit
- operates in forward and reverse
- has all key accessories mounted externally, allowing for simple and inexpensive maintenance.



The series

KPTB-HS

This high-speed drive is used primarily in medium and low power applications, and is available in sizes 15 and 17 (these numbers represent the nominal diameters of the working circuit in inches).

These units are also available in Low Temperature and Explosion Proof versions. A simple design combined with great reliability and performance makes this coupling a product with exceptional value. In addition, the KPTB-HS's versatile design allows you to configure a machine according to a customer's needs but still keep it within a tight budget. Features such as Viton® seals used throughout the drive and all main maintenance components externally mounted for easy access add even more to this unit's value.

KSL-HS

This high-speed drive is used primarily in medium and high power applications, and is available in size 21 and 24.

These units can be purchased with an optional auxiliary lubrication system that supplies oil to the motor and driven machine bearings. Low Temperature and Explosion Proof versions are available as well. Features on these units that provide durability and ease of maintenance are labyrinth seals, steel piping, externally accessible maintenance components, and horizontally split exterior housing (allows maintenance & repair without disturbing alignment).

Today, KSL and KPTB couplings are installed in hundreds of applications worldwide providing its user with unsurpassed performance and reliability. Profiting from these experiences, the new HS series of hydrodynamic couplings have been designed to work in most extreme conditions to ensure decades of reliable, economical and efficient service.

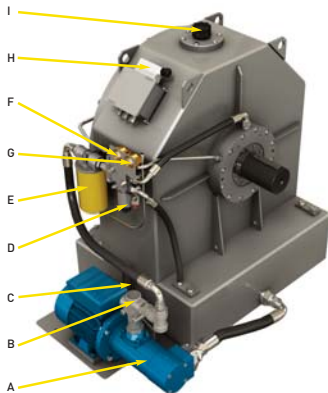
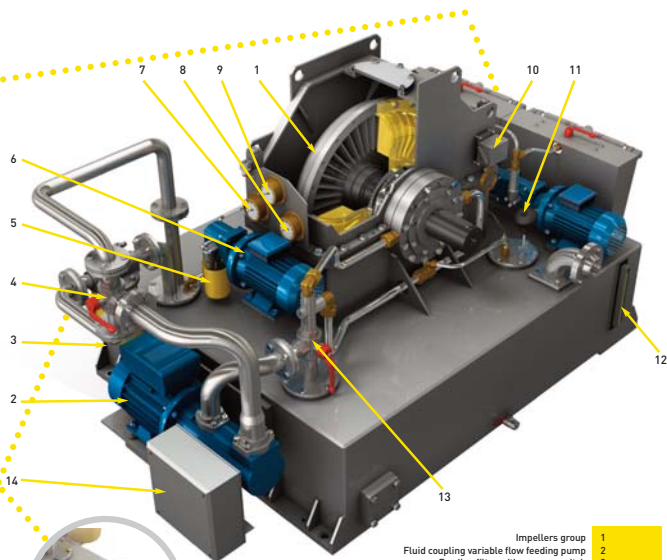
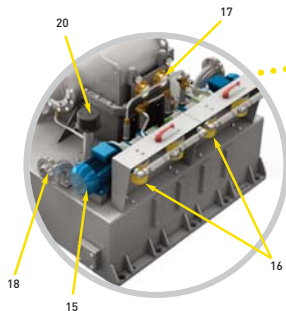

Impellers group	1
Fluid coupling variable flow feeding pump	2
Feeding filter with vacuum switch	3
Feeding filter by-pass valve	4
Lubrication filter with differential pressure transducer	5
Fluid coupling lubrication pump	6
Feeding pressure gauge	7
Temperature gauge	8
Lubrication pressure gauge	9
Oil temperature switch	10
Thermoresistance PT100	11
Oil level	12
Manual control valve	13
Feeding pump emergency manual control panel	14
Driven / driving machine bearings lubrication pump	15
Duplex filter group and lubrication oil pressure / flow regulation valves	16
Driven / driving machine bearings lubrication oil from driven / driving machine	17
Bearings lubrication oil from driven / driving machine	18
Oil level switch	19
Oil breather	20

Feeding pump	A
Thermostatic valve	B
Oil level	C
Feeding solenoid valve	D
Oil filter with differential pressure transducer	E
Temperature gauge	F
Feeding pressure gauge	G
Electrical panel for customer interface	H
Oil breather	I

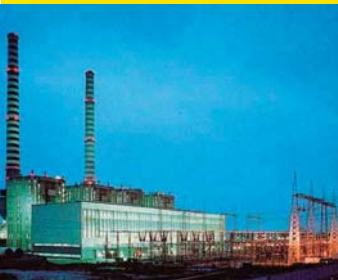

Working scheme

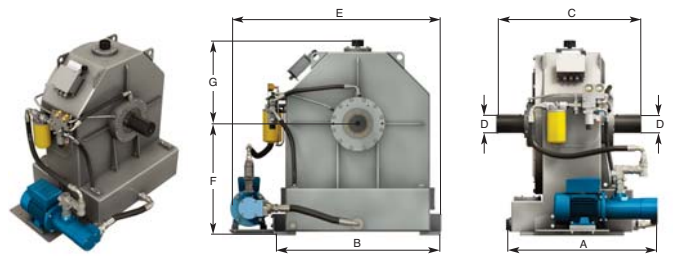
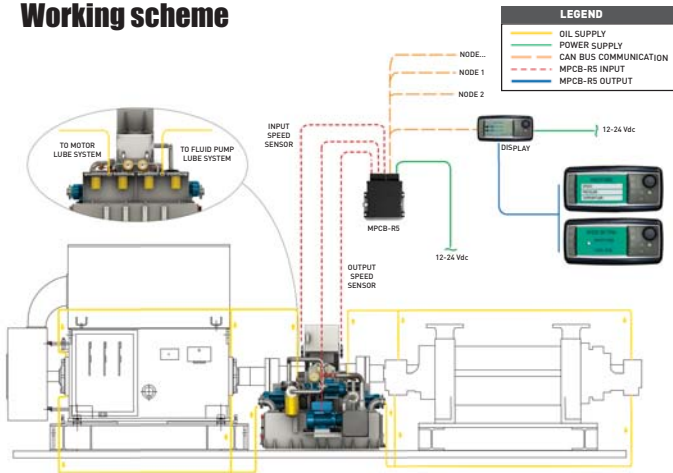

MODEL size	A	B	C	D	E	F	G	MOTOR POWER kW	SPEED rpm	WEIGHT w/o OIL
17KPTB-HS	770	800	636	75	1140	580	420	560 600	3000 3600	500

Without integrated auxiliary lubrication system

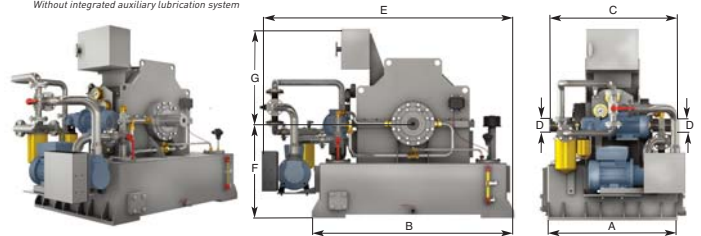

MODEL size	A	B	C	D	E	F	G	MOTOR POWER kW	SPEED rpm	WEIGHT w/o OIL
21KLS-HS	940	1500	920	100	1900	700	700	1600 2000	3000 3600	1500

Without integrated auxiliary lubrication system

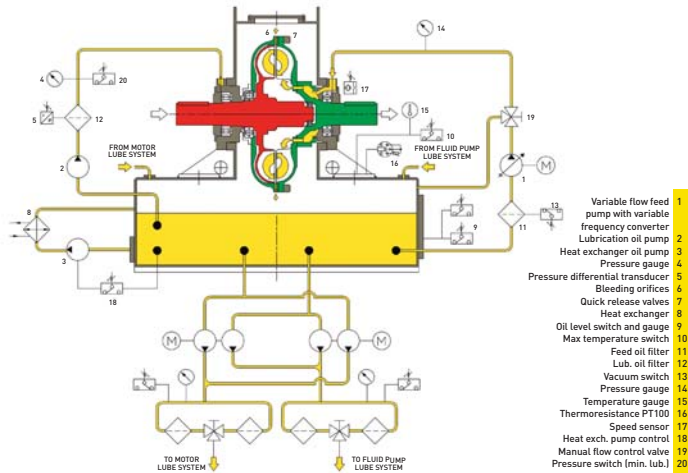

- 1 Variable flow feed pump with variable frequency converter
- 2 Lubrication oil pump
- 3 Heat exchanger oil pump
- 4 Pressure gauge
- 5 Pressure differential transducer
- 6 Bleeding orifices
- 7 Quick release valves
- 8 Heat exchanger
- 9 Oil level switch and gauge
- 10 Max temperature switch
- 11 Feed oil filter
- 12 Lub. oil filter
- 13 Vacuum switch
- 14 Pressure gauge
- 15 Temperature gauge
- 16 Thermoresistance PT 100
- 17 Speed sensor
- 18 Heat exch. pump control
- 19 Manual flow control valve
- 20 Pressure switch [min. lub.]

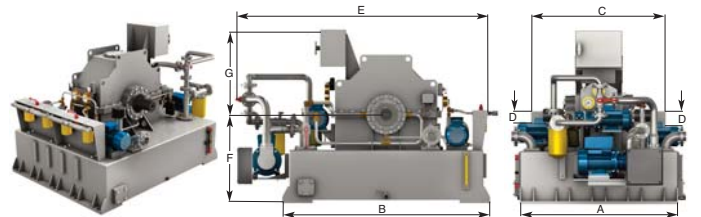

MODEL size	A	B	C	D	E	F	G	MOTOR POWER kW	SPEED rpm	WEIGHT w/o OIL
21KLS-HS	1300	1710	920	100	2080	725	700	1600 2000	3000 3600	1700
24KLS-HS								2600 3200	3000 3600	2200

With integrated auxiliary lubrication system