

TRANSFLUID

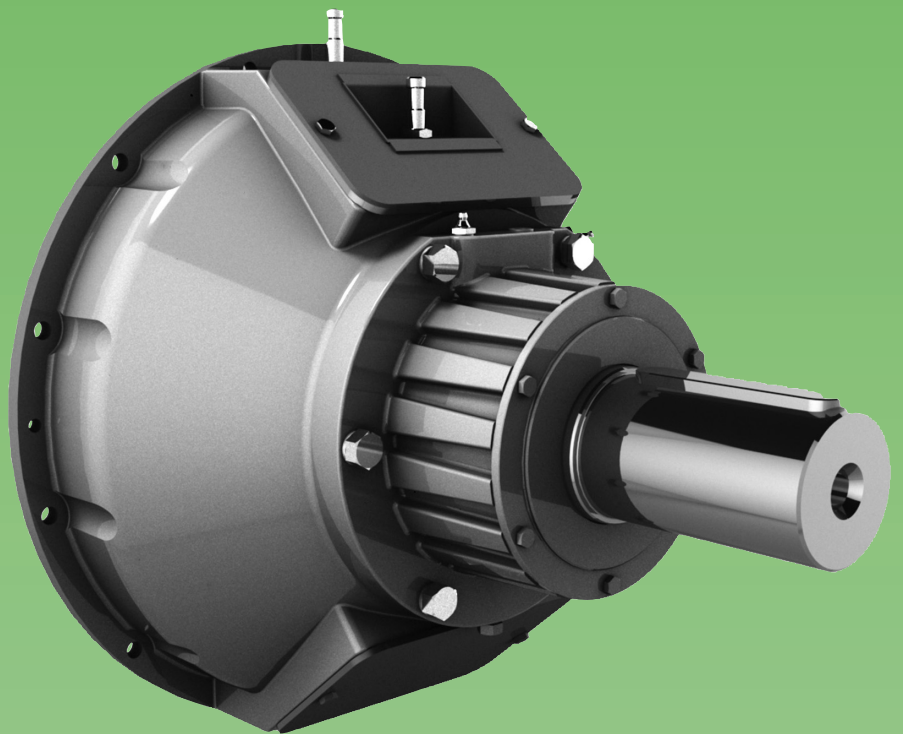

TRANSFLUID

trasmissioni industriali



drive with us

HF
OIL/AIR ACTUATED POWER TAKE OFF

HF POWER TAKE OFF

HFO - FOR SIDE LOAD APPLICATIONS

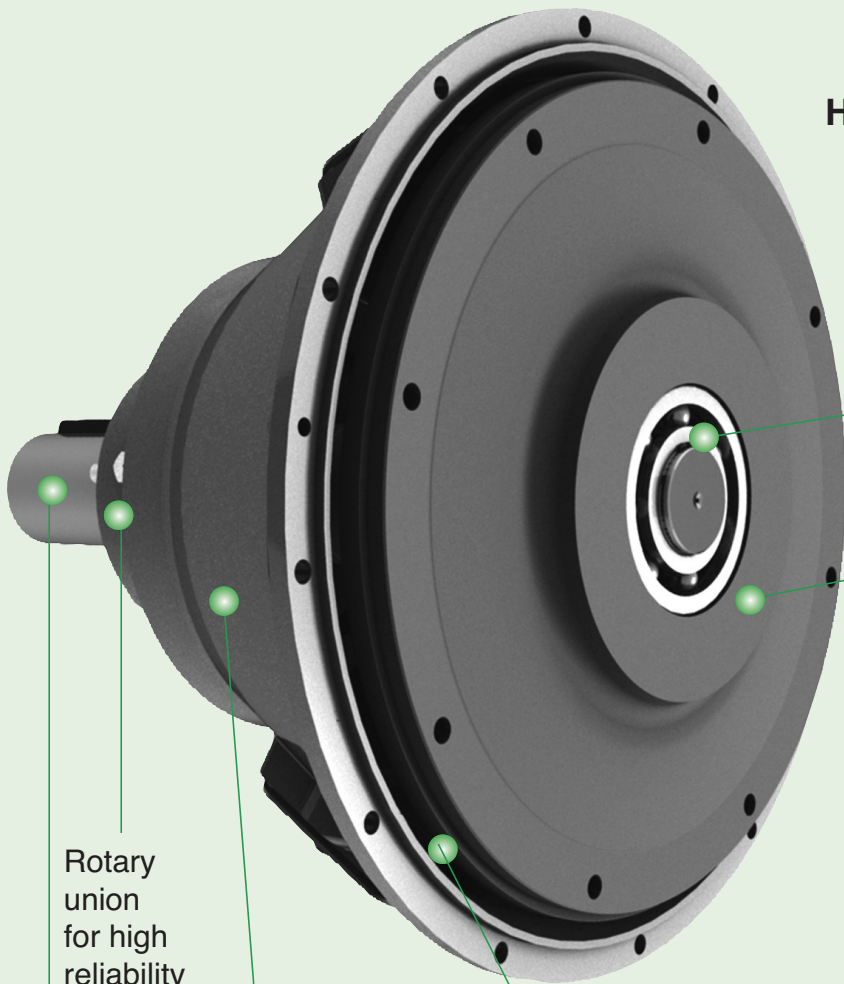

Unique greased for life bearing design

Eliminate the pilot bearing inside the engine flywheel

Rotary union for high reliability

Large bearings for high side load capacity

Rotary union protection (for 314 only)

Self adjusting clutch
Easy maintenance due to clutch pack design

Grease lubrication

HFR -
-

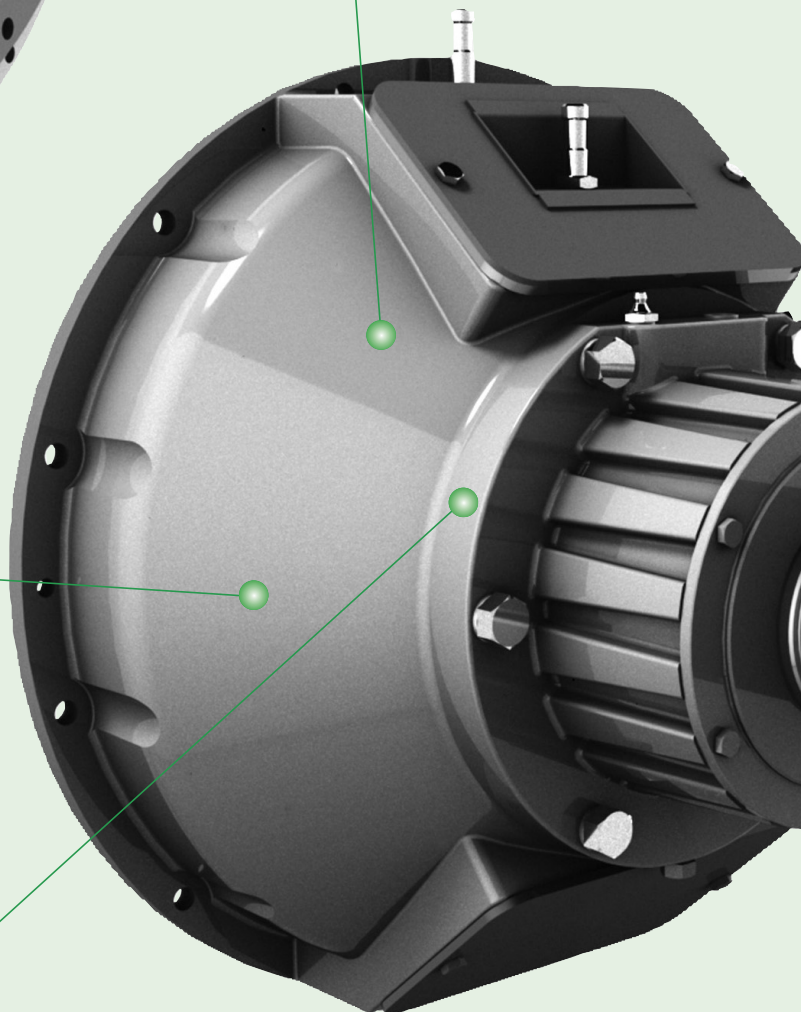

OIL / AIR ACTUATION

- remote control operation by push button engagement
- self adjusting; no operator adjustment required

UNIQUE CLUTCH DESIGN

- compact design
- high torque capacity
- eliminates the engine flywheel pilot bearing (HFO)
- no side load on flywheel (HFR)
- SAE standard interface
- dust proof for harsh environmental conditions
- simplified service in case of discs replacement
- easy installation
- available with Kevlar friction discs for heavy duty and torsionally active applications

FOR SIDE LOAD AND IN-LINE
SELF SUPPORTING DESIGN
ELIMINATES SIDE LOADS ON
THE ENGINE FLYWHEEL

OPTIONALS

- MPCB R5 microprocessor controller for 12 to 24 Vdc systems with advanced clutch protection, operation and monitoring. Integrated hydraulic and air power pack drive logic, event logging (latest 1000 events registration), controlled engagement monitoring (including soft start granting full driveline protection), clutch overload protection, engine and load speed display and real time data acquisition capability. Communication via CAN BUS 2.0 extended according to SAE J1939 protocol.
The display CAN BUS SAE J1939 is available as an option.
- Hydraulic and air power pack, 12 or 24 Vdc, with motor relay, pressure switch and indicator.
Avoids complicated actuation hydraulic circuits or modifications to existing ones.
Compact, light, reliable and with reduced maintenance. Particularly useful in retrofitting applications.

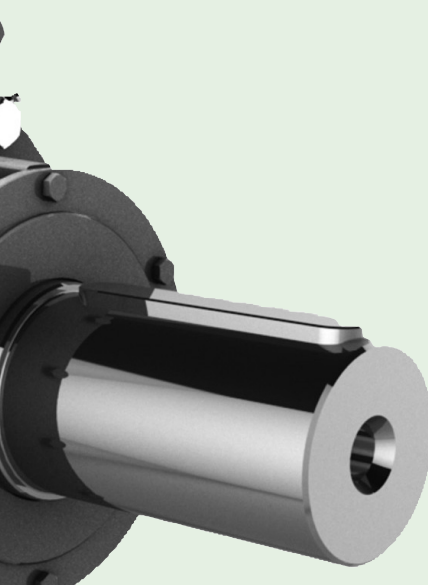

MPCB R5

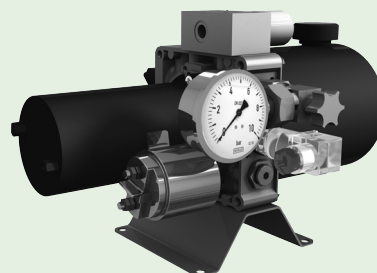

Hydraulic power pack



Air power pack

HFO OIL ACTUATED POWER TAKE OFF

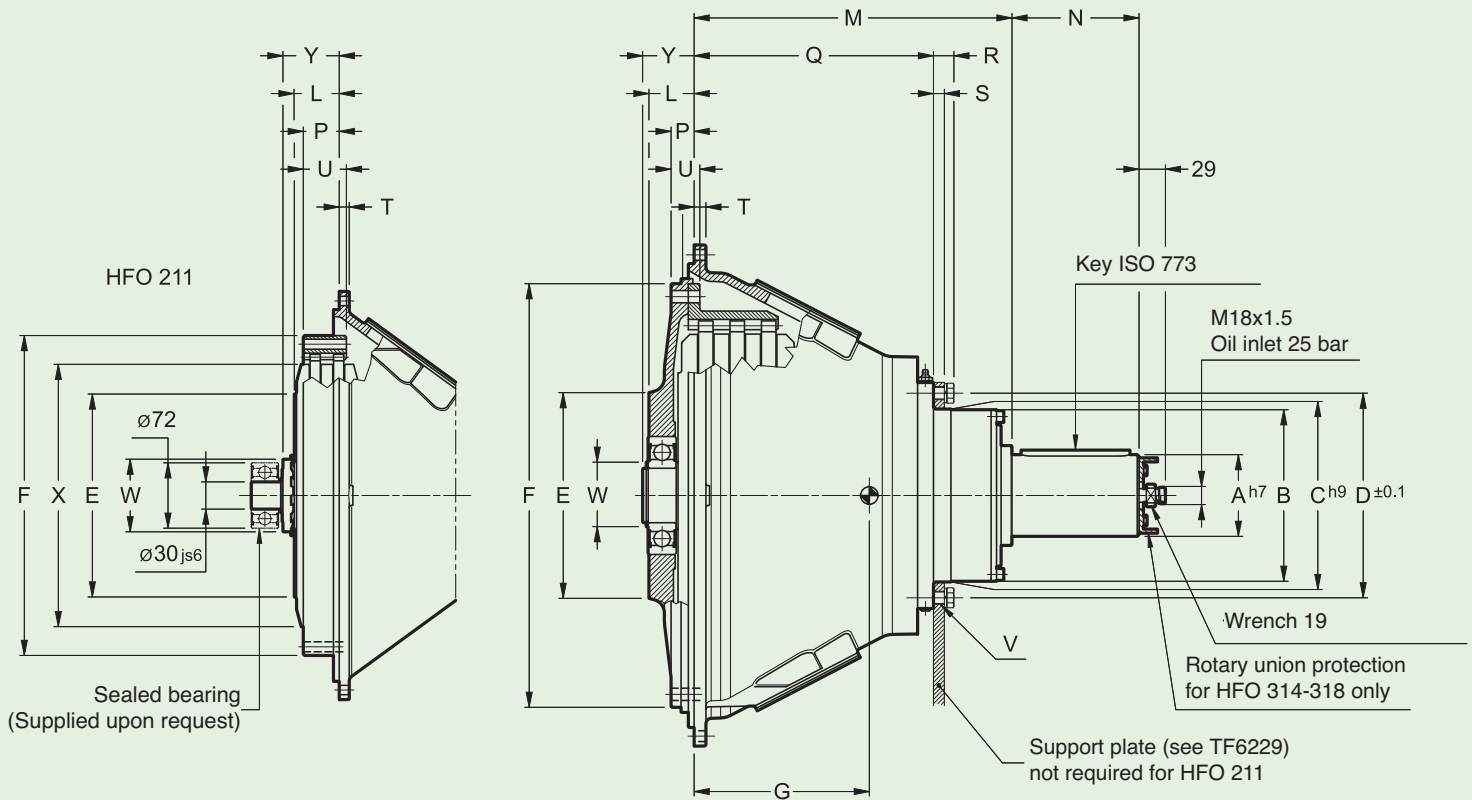

Dimensions																						
SIZE	SAE Housing size	SAE Flywheel size	A	B	C	D	E	F	L	M	N	P	Q	R	S	T	U	V		X	Y	W
																		Ø	Nr			
211	3	11 1/2"	70	137	-	-	223.5	352.4	49.5	235	140	39.6	-	-	-	11	47.6	-	-	289	63	85
311	3-2-1		80	189	190.5	225.4	113		66	270			182.5	23	12	88	13.5	6x60°	-	71	60.8	
214	1-0	14"	90	236	245	275	225.5	466.7	49.9	350.3	25.4	263.8	27	15	12.7	31.7	15		-	-	-	56.8
314																						

Technical data						
SIZE	MAX SPEED rpm	MAX INPUT TORQUE (at 25 bar) Nm	THERMAL CLUTCH CAPACITY Q	OUTPUT BEARING LUBRICATION	WEIGHT kg	CENTER OF GRAVITY G dimension
211	2500	1400	514	Grease	79	64
311	2400	2250	747	Grease	116	110
214	2400	3250	754	Grease	134	133
314	2400	4900	1128	Grease	167	130

- For permissible radial loads see selection instructions
 - Dimensions are subject to alteration without notice

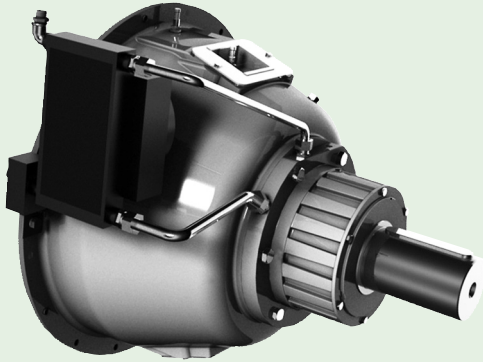

HFR OIL/AIR ACTUATED POWER TAKE OFF

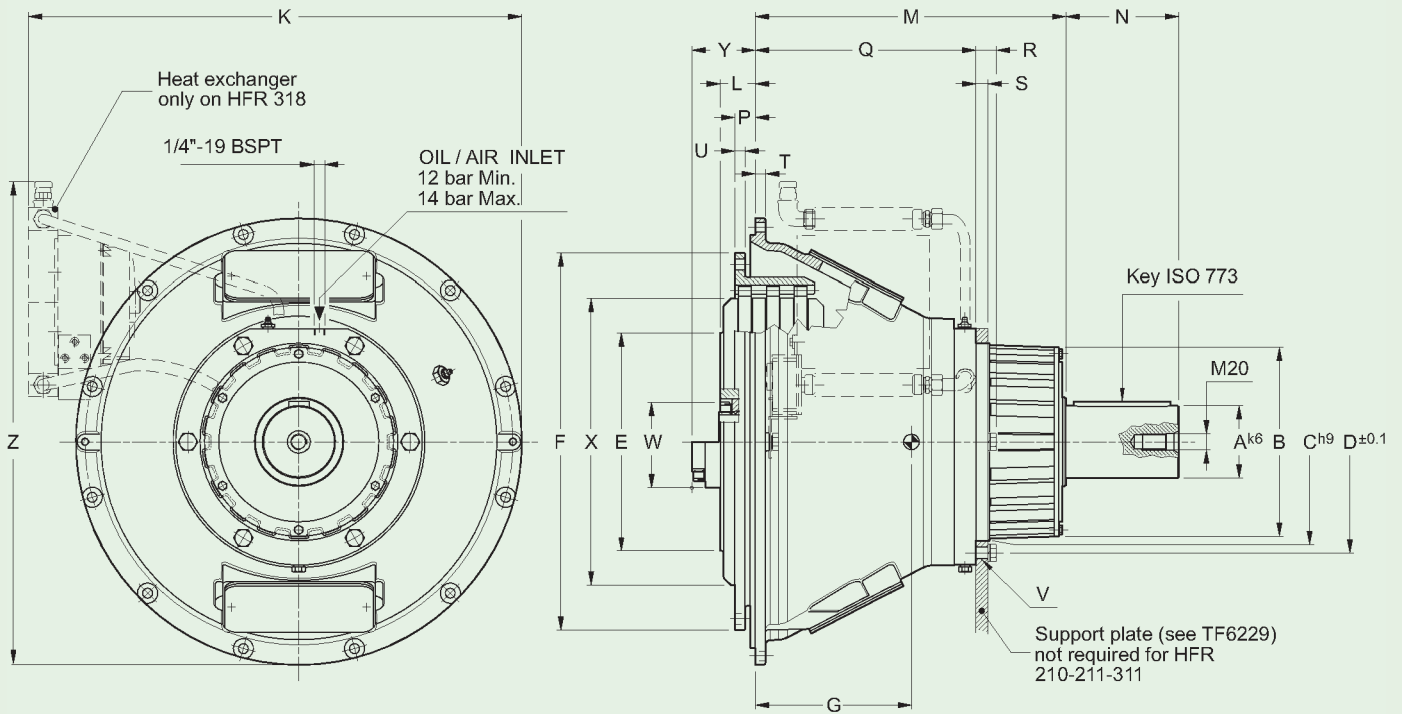

Dimensions																								
SIZE	SAE Housing size	SAE Flywheel size	A	B	C	D	E	F	L	M	N	P	Q	R	S	T	U	V		X	Y	W	K	Z
																		Dia	Nr					
210	4	10"	60	155	-	-	90	314.3	63	220	110	53.8	-	-	-	11	47	-	-	254	83	70	-	-
211	3-2	11 1/2"	-	-	-	-	-	352.4	54.5	235	-	39.6	-	-	-	12	47.5	-	-	289	68	-	-	-
311	3-2-1		80	177	-	-	223.5	49.5	280	-	140	-	-	-	-	12	80	-	-	63.5	90	-	-	-
314	1-0	14"	90	234	245	275	270	466.7	43.2	384.8	-	25.4	273.3	27	15	12.7	12.7	15	6x60°	355	45.2	75	-	-
318*	0	18"	110	258	265	305	385	571.5	40	515	180	15.7	380	32	18	14	16	17	6x60°	457	45	85	766	750

Technical data						
SIZE	MAX SPEED rpm	MAX INPUT TORQUE (at 12 bar) Nm	THERMAL CLUTCH CAPACITY Q	OUTPUT BEARING LUBRICATION	WEIGHT kg	CENTER OF GRAVITY G dimension
210	2800	1300	517	Grease	63	48
211	2800	1400	514	Grease	78	54
311	2800	2250	747	Grease	127	84
314	2100	4900	1128	Grease	206	137
318*	2100	7750	1980	Grease	368	155

* Kevlar discs as standard
 - For permissible radial loads see selection instructions
 - Dimensions are subject to alteration without notice

HF OIL-AIR ACTUATED POWER TAKE OFF

HFO oil supply 25 bar side load application

The HFO clutches have been developed by Transfluid to meet the growing market demand for power take offs applied to high speed, high horse power industrial engines and having remote control operation.

The HFO consists of an oil actuated clutch assembly (dry plates) with a shaft and bearings suitable for high side loads mounted in a cast iron housing that provides easy engine installation.

The clutch actuation is provided by a rotating union mounted in the output shaft .

This system allows the use of HFO for belt driven applications only. The oil actuation permits remote control as well as a larger transmittable torque compared to the traditional overcenter PTOs. In addition, due to the continuous pressure applied to the clutch plates, the HFO is a self adjusting clutch which drastically reduces the maintenance costs especially on heavy duty applications where plate wear is typical.

Additional to the HFO is the HFF design (flanged shaft by QD). This model is designed for road milling machines where a compact layout is required.

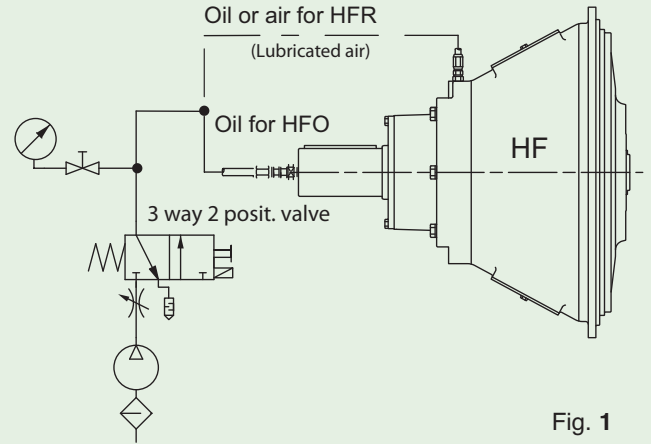

Fig. 1

HFR oil/air supply 12 bar in-line and side load application

The HFR clutches have been designed to complete the TRANSFLUID range of power take offs for new potential markets.

The oil-air actuation is provided by oil or air radial inlet instead of axial as the HFO: this configuration permits the mounting of couplings and/or cardan shafts on the output shaft.

The actuation oil or air is controlled externally and enters the clutch radially directly into the bearing carrier.

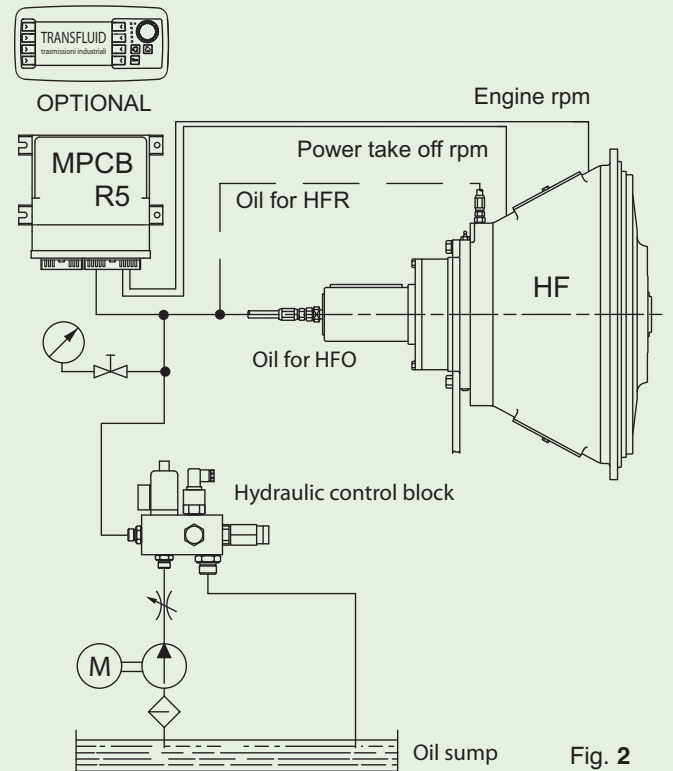

Fig. 2

Control and management of the HFO-HFR equipment:

- By customer hydraulic circuit (fig.1)
- By Power Pack, a compact power system that deliver oil in pressure (fig.2) or Air Pack, is a compact power system that delivers air in pressure
- By MPCB R5 with hydraulic control block, through continuous monitoring of some parameters proper transmission operation is assured. Any abnormal condition is promptly detected and countermeasures quickly enforced to protect the transmission as well as the engine (fig.3)
- By MPCB R5 with Power Pack or Air Pack (fig.4)

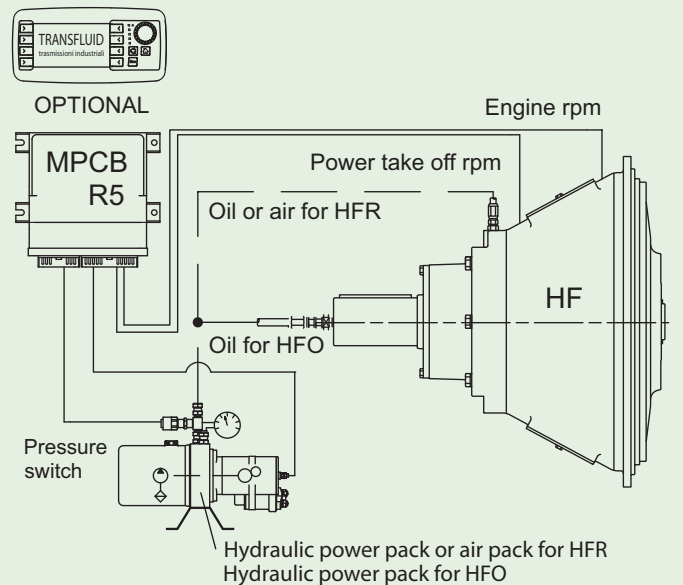

Fig. 4

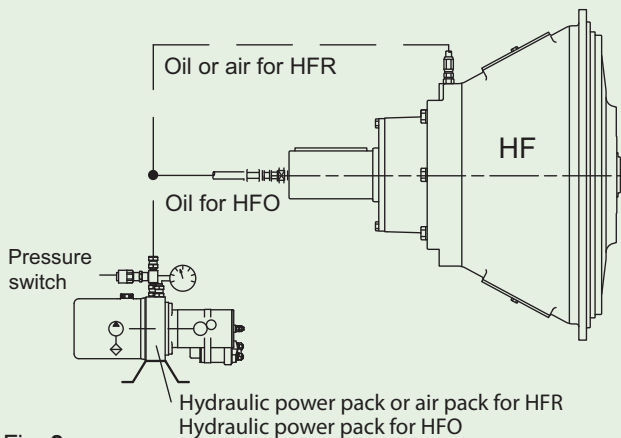

Fig. 3

SELECTION GUIDE

TABLE 1

APPLICATION FACTOR F *	PRIME MOVER				Driven machine load classification
	Multi cylinder Internal combustion engine		Multi cylinder Internal combustion engine with high torque rise		
	Up 10 hours/day	Over 10 hours/day	Up 10 hours/day	Over 10 hours/day	
1.25	1.5	1.75	2	Uniform load	
1.5	1.75	2	2.25	Moderate shock	
2	2.25	2.5	2.75	Heavy shock 1	
2.25	2.5	2.75	3	Heavy shock 2	

* According to AGMA standard

STEP 1 - QUICK SELECTION

- Uniform load : marine propulsion, fan, centrifugal pump, compressor, generator, water jet.
- Moderate shock : road milling machine, cone crusher, volumetric pump, snow blower, drill, pump for dredge.
- Heavy shock 1 : jaw crusher, impactor, wood chipper, shredder, grinder, hammer mills.
- Heavy shock 2 : reciprocating compressor, piston pumps.

F : application factor (see table 1)

kW : gross engine power (kW)

n : speed (rpm)

$$P = kW \cdot F$$

PTO - Selection Chart 1

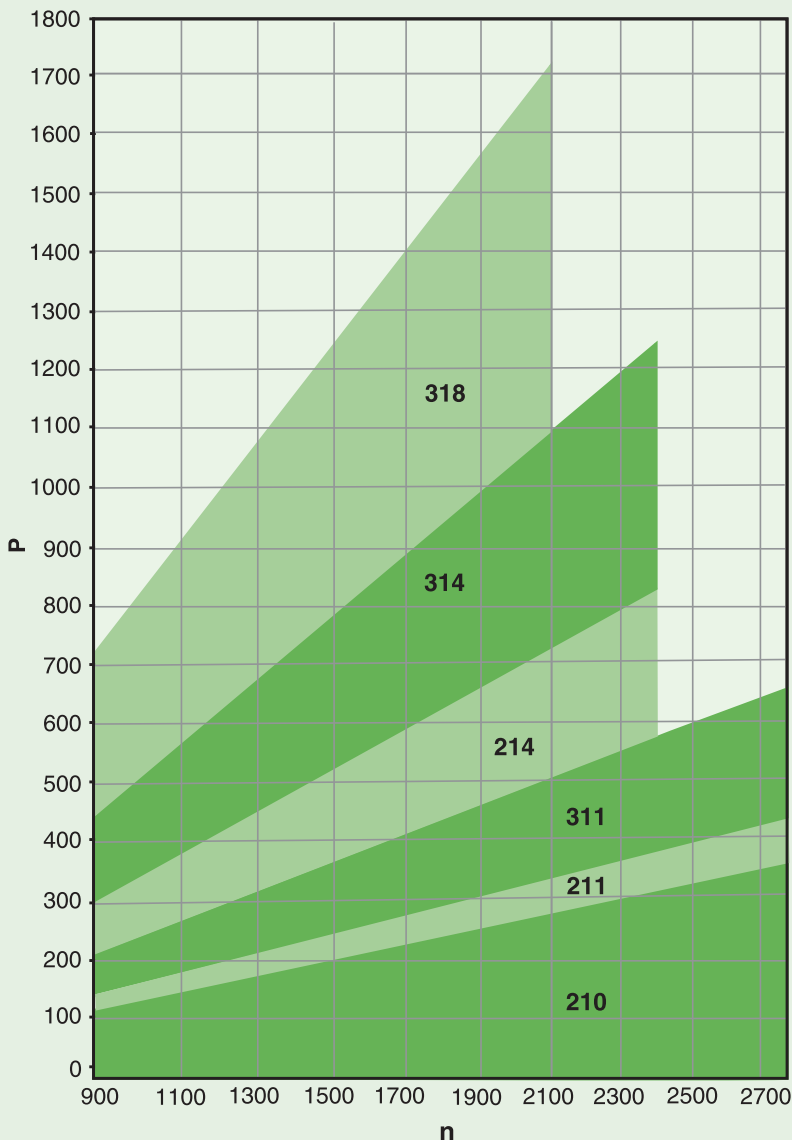

- PTO engagement has to be performed at approximate engine idling speed.
- Interval between starts should be 1 hour minimum (fluid coupling mounted on the PTO output shaft allows 3 starts/hour evenly spaced).
- For other technical information, consult the Installation and Maintenance Manual.

KEVLAR FRICTION DISCS:

- For heavy duty and torsionally aggressive applications, the use of Kevlar discs is recommended.
- For side load applications HFR with Kevlar discs must be used.

STEP 2 - THERMAL CAPACITY VERIFICATION

T : max input torque (Nm) - see table pages 3 & 4

J : inertia (kgm²) = GD²/4

t : starting time (seconds) - actual slip

Q : thermal clutch capacity - see table pages 3 & 4

$$t = \frac{J \cdot n}{9.55 \cdot T}$$

$$kW \cdot t \leq Q$$

In case of higher Q value than stated in the technical data table (see pages 3 & 4), size of the clutch has to be revised.

- 0.746 kW = 1 hp
- 25.4 mm = 1 inch
- 0.042 kgm² = 1 lbs · ft²
- 1.356 Nm = 1 lbs · ft

HF OIL-AIR ACTUATED POWER TAKE OFF

STEP 3 - HFO/HFR PERMISSIBLE SIDE LOAD CHART 2

- Calculated bearing life over 5000 hours
- Rim speeds over 35 m/s, the dynamic balancing of the pulley is recommended
- Timing belts must be approved by Transfluid
- "X" distance is according to belt type & number
- HFR with Kevlar discs only

Actual applied side load "T"

$$(a) T \text{ [kN]} = \frac{S \cdot kW \cdot L \cdot 191 \cdot 100}{D \cdot n}$$

D : pulley pitch diameter (mm)

kW: gross engine power (kW)

n : (rpm)

S : service factor

L : life factor

Service Factor	S
Chain or gear drive	1.0
V-Belts	2.2

Life Factor	L
Cyclic and shock loads	2.1
High-medium side load	1.8
Low side load	1.2
Medium-low side load (hydraulic belt tensioner)	0.9

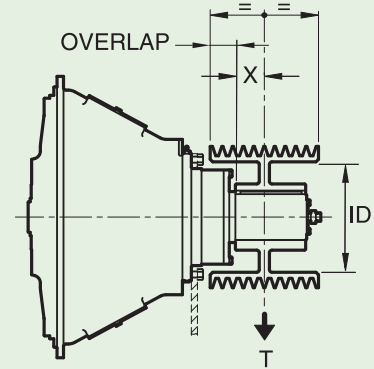

TABLE 2

HFO	Max overlap allowable* [mm]	Min pulley ID* [mm]
211	47	137
311	65	189
214	63.5	189
314	50	245

TABLE 3

HFR	Max overlap allowable* [mm]	Min pulley ID* [mm]
210	71	155
211	71	155
311	83	177
314	83	233
318	102	263

* Dimensions are limits. Space for rotating parts must be added.

IMPORTANT NOTICE

- Disregarding system torsional compatibility could cause damage to components in the drive train resulting in loss of mobility or power transmission for which the drive is intended. At minimum, system torsional incompatibility could result in unwanted noise and vibration at low speeds.

- The responsibility for ensuring that the torsional load of the system is satisfactory rests with the assembler of the drive and driven equipment.
- The acceleration of large inertial loads may require special applications or downsizing of the intended units. Transfluid is prepared to assist in finding solutions to potential inertial problems that relate to the power take-off.

PERMISSIBLE SIDE LOAD T vs X DISTANCE Chart 2

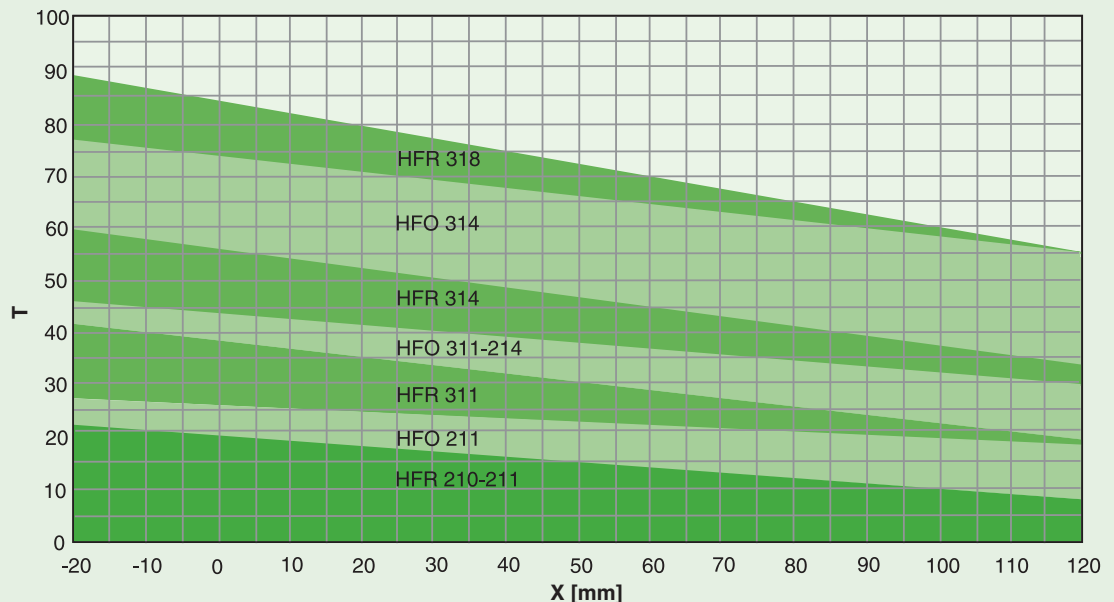

Selection of HFR/HFO based on permissible side load:

- Calculate side load with formula (a).
- Enter side load and X distance.
- Select clutch.

EXAMPLE:

T side load= 65 kN
X distance = 30 mm
select HFO 314

- Clutch reference speed in Chart 2 is 2100 rpm.

- If the engine speed is higher than above indicated value, contact Transfluid for application approval.

FRANCE

TRANSFLUID FRANCE s.a.r.l.
38500 Voiron
Tel.: +33.9.75635310
Fax: +33.4.26007959
tfrance@transfluid.it

RUSSIAN FEDERATION

TRANSFLUID OOO
Moscow
Tel.: +7.495.4966004
Mob.: +7.926.8167357
tfrussia@transfluid.it

U.S.A. & CANADA

TRANSFLUID LLC
Auburn, GA 30011
Tel.: +1.770.8221777
Fax: +1.770.8221774
tfusa@transfluid.it

BRAZIL

TRANSFLUID DO BRASIL
Representative Office
05014-060 Sao Paulo SP
Tel.: +55.11.48235308
Fax: +55.11.48235308
tfbrazil@transfluid.it

CHINA

TRANSFLUID BEIJING TRADE CO.
LTD
Beijing
Tel.: +86.60442301-2
Fax: +86.60442305
tbtinfo@sina.com