

TRANSFLUID

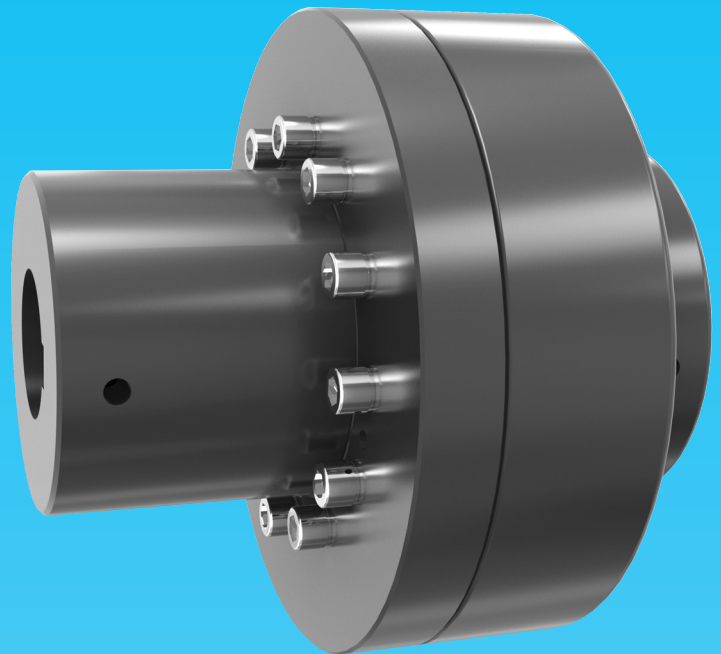

TRANSFLUID

trasmissioni industriali



drive with us

B3M-BM-BMS
FLEXIBLE COUPLINGS

GENERAL DESCRIPTION

With decades of experience and thousands of applications on TRANSFLUID fluid couplings the BT flexible coupling line has been expanded to include couplings for shaft-to-shaft application. The new series has been studied to provide an exceptionally robust coupling with excellent misalignment capabilities and easy installation and assembly. The B3M/BM/BMS couplings high quality flexible elements provide reliable performance while protecting the coupled machines.

The B3M/BM/BMS require minimal maintenance except for a periodical inspection and replacement of the rubber elements. To simplify in this check, especially in alignment free drives, the B3M was developed. This version allows for inspection and removal of the rubber elements while preserving alignment.

Manufactured with the highest quality materials in TRANSFLUID's new factory in Gallarate Italy the new B3M/BM/BMS series is available in 17 different sizes with torque capability exceeding 33100Nm (24,494 lbs-ft)

ADVANTAGES:

- Compensation of misalignments
- Shocks and vibrations damping
- Fail - safe and capable of withstanding high overloads
- Quick and easy change of flexible elements
- Maintenance free

B3M

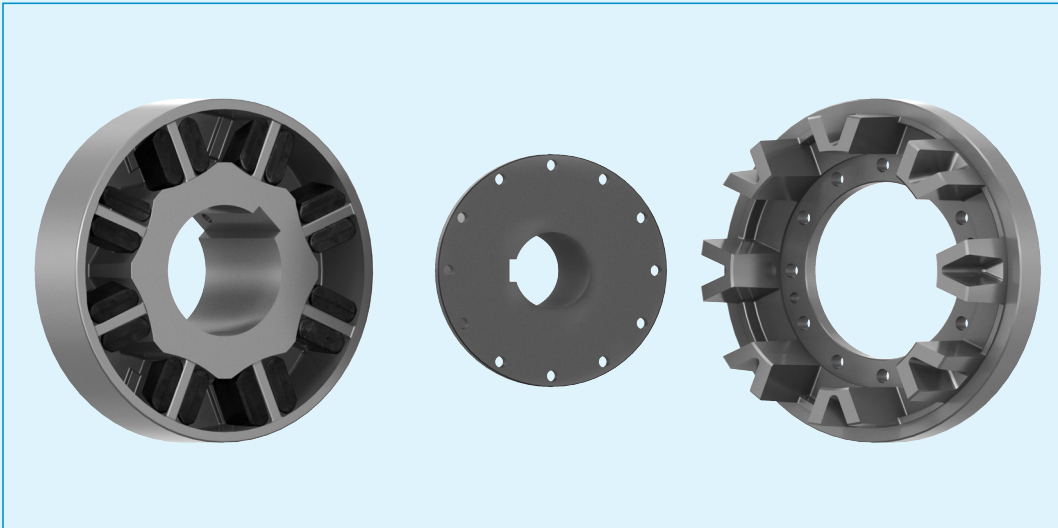

B3MBP

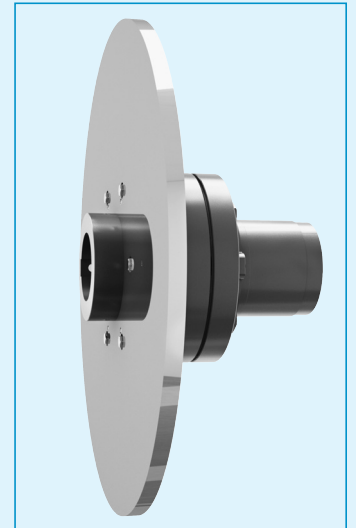

BM

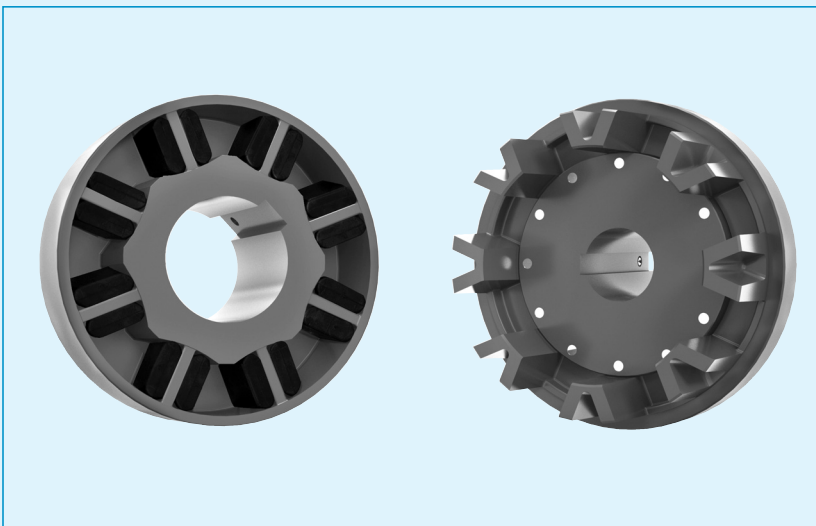

BMS

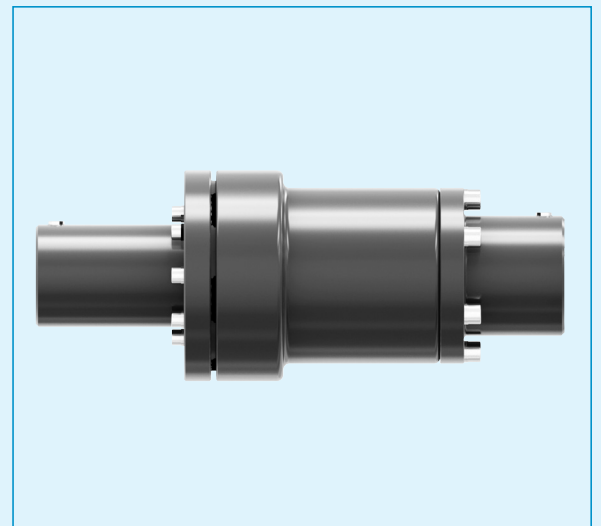

Shaft couplings

Standard version for connecting two shafts. The **B3M** allows changing of flexible elements with no need for axial movement of either of the couplings hubs.

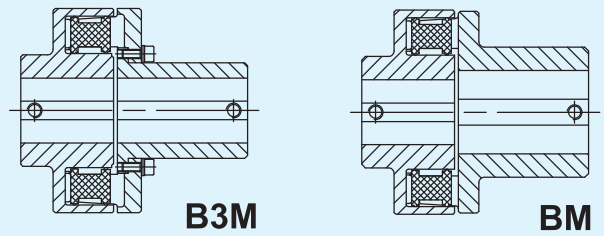

Brake drum couplings

With brake drum.
See **Catalogue 355** for **TRANSFLUID BRAKES**.

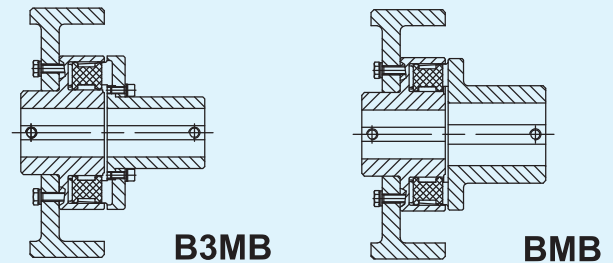

Brake disc couplings

With brake disc.
See **Catalogue 355** for **TRANSFLUID BRAKES**.

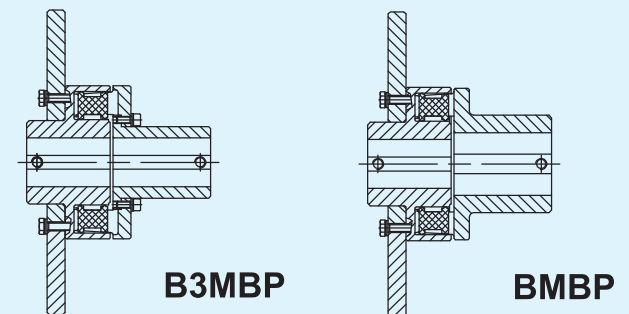

Spacer couplings

B3M with removable spacer.

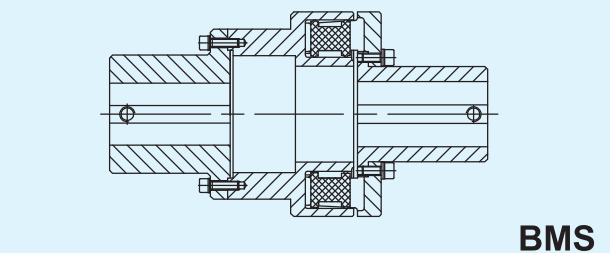

Combination

For connection with a Transfluid fluid coupling.

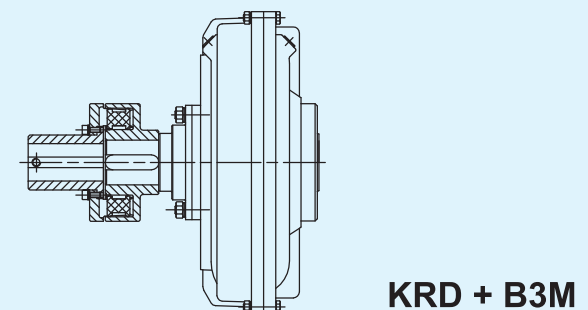

ATEX

It is possible to get BM series couplings, **with finished bores**, certified as equipment for intended use in hazardous zones according to directive 94/9/EC (ATEX), surface applications categories Ex II 2D/G T4 and Ex II 3D/G T4. The selection of ATEX coupling must consider an additional safety factor (S_{Atex}) as mentioned at page 4.

TECHNICAL DATA

Tab. 1

Coupling size	Technical data for standard rubber elements						
	Nominal torque T _{KN}		Maximum torque TK _{max}		Dynamic torsional stiffness CT _{dyn}		Max. (*) N _{max} (rpm)
	(Nm)	(lbs-ft)	(Nm)	(lbs-ft)	(Nm/rad)	(lbs-ft/rad)	
01	20	15	40	30	2000	1480	5000
02	55	41	110	81	3000	2220	5000
05	75	56	150	111	5200	3848	5000
10	160	118	320	237	14800	10952	5000
20	320	237	640	474	25100	18574	5000
40	630	466	1260	932	63000	46620	4000
43	630	466	1260	932	41800	30932	4000
45	940	696	1880	1391	82200	60828	3600
48	1480	1095	2960	2190	90700	67118	3600
50	2060	1524	4120	3049	209700	155178	3000
53	2060	1524	4120	3049	106600	78884	3000
55	3160	2338	6320	4677	187400	138676	3000
60	5220	3863	10440	7726	412400	305176	2200
70	7650	5661	15300	11322	627600	464424	2000
80	11550	8547	23100	17094	936100	692714	1800
90	21030	15562	42060	31124	971400	718836	1800
95	33100	24494	66200	48988	1956000	1447440	1500

*Referred to standard materials

Tab. 2 - IEC electric motors

Motor			Motor power at 1500 rpm		Coupling size
Size	Shaft dia. (mm)	Shaft length (mm)	Power (kW)	Torque (Nm)	
56	9	20	0.06	0.4	01
			0.09	0.57	01
63	11	23	0.12	0.76	01
			0.18	1.15	01
71	14	30	0.25	1.60	01
			0.37	2.5	01
80	19	40	0.55	3.50	01
			0.75	4.50	01
90S	24	50	1.1	7.00	02
90L	24	50	1.5	10.00	02
100L	28	60	2.2	14.00	02
			3	19.00	02
112M	28	60	4	25.50	02
132S	38	80	5.5	35.00	10
132M	38	80	7.5	48.00	10
160M	42	110	11	70.00	10
160L	42	110	15	95.50	10
180M	48	110	18.5	118.00	20
180L	48	110	22	140.00	20
200L	55	110	30	191.00	20
225S	60	140	37	235.50	20
225M	60	140	45	286.50	20
250M	65	140	55	350.00	40
280S	75	140	75	477.50	48
280M	75	140	90	573.00	48
315S	80	170	110	700.00	48
315M	80	170	132	840.50	48
			160	1020.00	48
355S	100	210	250	1595.00	60
355M	100	210	315	2005.00	60

Tab. 2A - NEMA electric motors

Motor			Motor power at 1800 rpm		Coupling size
Size	Shaft dia. (inch)	Shaft length (inch)	Power (hp)	Torque (lbs-ft)	
143T	0.875	2.250	1	2.92	02
145T	0.875	2.250	1.5	4.38	02
			2	5.84	02
182T	1.125	2.750	3	8.75	02
184T	1.125	2.750	5	14.59	02
213T	1.375	3.375	7.5	21.88	10
215T	1.375	3.375	10	29.18	10
254T	1.625	4.000	15	43.77	10
256T	1.625	4.000	20	58.36	10
284T	1.875	4.625	25	72.95	20
286T	1.875	4.625	30	87.54	20
324T	2.125	5.250	40	116.71	20
326T	2.125	5.250	50	145.89	20
364T	2.375	5.875	60	175.07	40
365T	2.375	5.875	75	218.84	40
405T	2.875	7.250	100	291.78	48
444T	3.375	8.500	125	364.73	60
445T	3.375	8.500	150	437.68	60
447T	3.375	8.500	200	583.57	60
447T	3.375	8.500	250	729.46	60
449T	3.375	8.500	300	875.35	60

Tab. 2-2A Selection based on max allowable bore of the flexible coupling, assuming value 1 for all factors (S_m, S_t, S_z, S_{Atex}). For applications where the factors are different from 1, the coupling must be properly selected according to selection procedure at page 4

The coupling must be selected so that the operating conditions of the coupling, do not exceed the maximum allowable load of the coupling itself. For driving machines not generating cyclic torque loads the selection of the coupling can be performed using the driving torque and the corresponding service factor. When the driving machine generates cyclic torque loads (e.g. internal combustion engines) the selection of the coupling must be checked by a torsional analysis of the complete system. Steps to be followed are as follows.

1) Using the power and rotational speed, calculate the torque of the driving machine T_{AN} :

where:

P = power of driving machine (kW) - n = rotational speed of driving machine (rpm)

T_{AN} = torque of driving machine (Nm)

$$T_{AN} = 9550 \times P / n$$

2) Once the torque of the driving machine T_{AN} has been calculated, determine the service factor and check that the torque of the driving machine times the service factor, temperature factor and starting factor is lower than the characteristic torque of the chosen coupling T_{KN} :

where:

T_{KN} = characteristic torque of the chosen coupling (Nm)- S_m = service factor from table Tab. 4 and Tab. 6

S_t = temperature factor from table Tab. 3 - S_z = starting factor from table Tab. 5

S_{Atex} = 1,2 in case of use in hazardous zones acc. to 94/9/EC (Atex). In normal zones, S_{Atex} = 1

$$T_{KN} \geq T_{AN} \times S_m \times S_t \times S_z \times S_{Atex}$$

Load classifications and service factors of Tab. 6 are referred to turbines and hydraulic or electric motor as the prime mover. If the prime mover is a single or multi cylinder engine, the service factor from the Tab. 6 must be replaced by its corresponding value from Tab. 4

Tab. 3 - Temperature factor

Ambient temperature	-40 °C +30 °C	+40 °C	+60 °C	+80 °C	>+80 °C
	-40° F +86° F	+104°F	+140 °F	+176 °F	>+176 °F
S_t	1.0	1.1	1.4	1.8	on request

Tab. 5 - Starting factor

Starting frequency per hour	30	60	120	240	>240
S_z	1.0	1.1	1.2	1.3	on request

3) Known the maximum possible torque during operation T_{max} , check that the maximum torque times the temperature factor is lower than the maximum characteristic torque of the chosen coupling T_{Kmax} :

$$T_{Kmax} \geq T_{max} \times S_t$$

Calculation example

1) Application data

A torsionally elastic coupling type **BM** installed between an electric motor and a rotary pump gear type.

Power of the electric motor: $P = 160$ kW

Rotational speed: $n = 1490$ rpm

2) Calculation of driving torque T_{AN}

The driving torque T_{AN} of the driving machine is:

$$T_{AN} = 9550 \times 160 / 1490 = 1025 \text{ Nm}$$

3) Check of the nominal T_{KN}

From table Tab. 6 the service factor corresponding to the driven machine load classification is: $S_m = 1.5$. Because the prime mover is an electric motor, it is not necessary to use conversion table Tab. 4

From table Tab. 3 for an ambient temperature of 40 °C, the temperature factor is: $S_t = 1.1$

From table Tab. 5 for starting frequency per hour of 60 the starting factor is: $S_z = 1.1$

The nominal torque T_{KN} of the driving machine is:

$$T_{KN} \geq 1025 \text{ Nm} \times 1.5 \times 1.1 \times 1.1 = 1861 \text{ Nm}$$

4) Selection of the coupling

From table Tab. 1, with torque values $T_{KN} \geq 1861$ Nm the choice is for coupling size **BM 50**.

5) As final selection step, check compatibility between equipment shaft and max allowable bore of selected coupling

Tab. 4

Conversion table for single or multi-cylinder engines

Steam and gas turbines, hydraulic or electric motors (from Tab. 6)	Single cylinder engines	Multi-cylinder engines
1.00	1.50	1.25
1.25	1.75	1.50
1.50	2.00	1.75
1.75	2.25	2.00
2.00	2.50	2.25
2.25	2.75	2.50
2.50	3.00	2.75

LOAD CLASSIFICATION AND SERVICE FACTOR

Tab. 6 - Service factor for steam turbines, hydraulic or electric motors, as prime mover

Agitators					
Pure liquids	1.00				
Liquids and solids	1.25				
Blowers					
Centrifugal	1.00				
Lobe	1.50				
Vane	1.25				
Car dumpers	2.50				
Car pullers - intermittent duty	1.50				
Chemical industry					
Agitators	1.75				
Centrifuges (heavy)	1.75				
Centrifuges (light-weight)	1.25				
Cooling drums	1.75				
Drying drums	1.75				
Mixers	1.75				
Compressors					
Centrifugal	1.25				
Lobe	1.50				
Reciprocating -multi-cylinder	2.00				
Conveyors - uniform loaded					
Belt	1.00				
Bucket	1.25				
Chain	1.25				
Screw	1.25				
Conveyors - Not uniformly loaded					
Belt	1.25				
Bucket	1.50				
Chain	1.50				
Reciprocating	2.50				
Screw	1.50				
Table	2.00				
Cranes and hoists					
Main hoists	2.00				
Trolley drive	1.75				
Bridge drive	1.75				
Slope	1.50				
Crushers - Grinders	2.75				
Dredges					
Bucket conveyors	1.50				
Cable reels	1.75				
Cutter heads	2.25				
Maneuvering winches	1.75				
Pumps	1.75				
Screen drive	1.75				
Slewing gears	2.00				
Elevators					
Bucket	1.75				
Freight	2.00				
Gravity discharge	1.50				
Fans					
Centrifugal	1.00				
Cooling towers	2.00				
Forced draft	1.50				
Induced draft					
w/o damper control	2.00				
Feeders					
Belt	1.25				
Reciprocating	2.50				
Screw	1.25				
Food industry					
Beet slicer	1.75				
Filling machines	1.00				
Cereal cooker	1.25				
Dough mixer	1.75				
Meat grinders	1.75				
Bottling, can filling machine	1.00				
Generators, transformers					
Frequency transformers	2.00				
Generators	2.00				
Welding generators	2.00				
Laundries					
Washing machines	2.00				
Lumber industry					
Barkers - drum type	2.00				
Live rolls	2.00				
Log haul	2.00				
Off bearing rolls	2.00				
Slab conveyor	1.50				
Sorting table	1.50				
Trimmer feed	1.75				
Machine tools					
Bending roll	2.00				
Punch press - gear driven	2.00				
Tapping machines	2.50				
Other machine tools:					
Main drives	1.50				
Auxiliary drives	1.25				
Metal rolling mills					
Billet shears	2.25				
Chain transfers	1.50				
Cold rolling mills	2.25				
Continuous casting plants	2.00				
Ingot handling machinery	2.25				
Ingot pushers	2.25				
Manipulators	2.25				
Roller adjustment drivers	2.00				
Roller straighteners	2.00				
Sheet mills	2.25				
Trimming shears	2.00				
Tube welding machines	2.25				
Winding machines (strip and wire)	2.00				
Wire drawing benches	2.25				
Mixers					
Concrete mixers	1.75				
Drum type	1.50				
Oil industry					
Chillers	1.25				
Oil pipeline pumps	1.75				
Rotary drilling equipment	2.00				
Paper industry					
Barker	2.00				
Barking drum (spur gear only)	2.25				
Beater & pulper	1.75				
Bleacher	1.00				
Calenders	2.00				
Couch	1.75				
Cutters. platers	2.00				
Cylinders	1.75				
Dryers	1.75				
Felt stretcher	1.25				
Felt whipper	2.00				
Log haul	2.00				
Suction roll	1.75				
Washers and thickeners	1.50				
Wet presses	2.00				
Winders	1.50				
Printing presses	1.50				
Pullers	2.00				
Pumps					
Centrifugal	1.00				
Reciprocating	2.00				
Rotary - gear, lobe, vane	1.50				
Rubber calender industry					
Calender	2.00				
Mixer - Banbury	2.50				
Rubber mill	2.25				
Sheeter	2.00				
Tire building machines	2.50				
Tire & tube press openers	1.00				
Tubers and strainers	2.00				
Screens					
Air washing	1.00				
Rotary - stone or gravel	1.50				
Travel water intake	1.25				
Sewage disposal equipment	1.25				
Stone and clay working machines					
Ball mills	2.25				
Beater mills	2.25				
Breakers	2.25				
Brick presses	2.25				
Hammer mills	2.25				
Rotary kilns	2.00				
Tube mills	2.00				
Textile machines					
Batchers	1.50				
Looms	1.50				
Printing and dyeing machines	1.50				
Tanning vats	1.50				
Water treatment					
Aerators	1.00				
Screw pumps	1.50				
Wood working machines					
Debarking drums	2.00				
Planing machines	1.50				
Wood chippers	2.75				

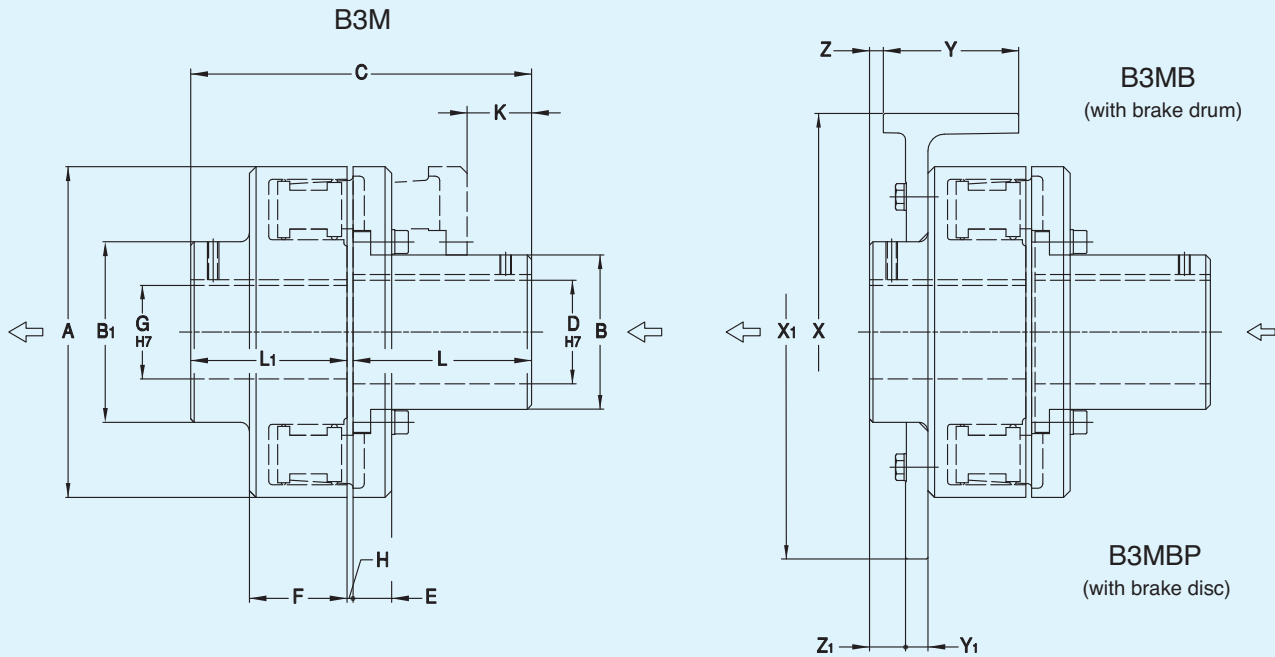

Tab. 7 Dimensions (mm)

Size 	D		G		L	L1	A	B	B1	C	E	F	H	K	Brake Drum mm		Z	Brake Disc mm		Z1	Rubber Element		Weight	INPUT	OUTPUT
	mm (inch)	mm (inch)	mm (inch)	mm (inch)	mm (inch)	mm (inch)	mm (inch)	mm (inch)	mm (inch)	mm (inch)	mm (inch)	mm (inch)	mm (inch)	mm (inch)	X	Y		X1	Y1		Type	Nr.	kg (lbs)	PD ² (kgm ²)	PD ² (kgm ²)
	Min	Max	Min	Max									••	(inch)											
20	-	48 (1.781)	-	55 (2.063)	110 (4.344)	80 (3.156)	132 (5.188)	64 (2.531)	85 (3.344)	192 (7.563)	17 (0.656)	42 (1.656)	2 (0.094)	64 (2.531)	200 250	75 95	5 -15	On request		-	C	12	8 (17.64)	0.022	0.023
43	-	50 (1.938)	-	60 (2.25)	110 (4.344)	80 (3.156)	150 (5.906)	70 (2.75)	90 (3.531)	193 (7.594)	17 (0.656)	43 (1.688)	3 (0.125)	59 (2.313)	250 315	95 118	-	400 450	30 30	7	S	12	9.5 (20.95)	0.028	0.029
45	-	60 (2.25)	-	65 (2.375)	110 (4.344)	80 (3.156)	175 (6.875)	80 (3.156)	100 (3.938)	193 (7.594)	20 (0.781)	42 (1.656)	3 (0.125)	60 (2.375)	250 315	95 118	-	400 450	30 30	7	S	16	14 (30.86)	0.074	0.076
48	-	75 (2.75)	35 (1.375)	70 (2.625)	110 (4.344)	80 (3.156)	185 (7.281)	100 (3.938)	110 (4.344)	193 (7.594)	23 (0.906)	52 (2.063)	3 (0.125)	42 (1.656)	250 315 400	95 118 150	-	400 450	30 30	-2	N	12	17.2 (37.91)	0.116	0.114
53	-	80 (3)	35 (1.375)	80 (3)	110 (4.344)	110 (4.344)	200 (7.875)	110 (4.344)	125 (4.906)	223 (8.781)	28 (1.094)	61 (2.406)	3 (0.125)	28 (1.094)	315 400 400	118 150 -40	-8	400 450	30 30	20	E	12	24 (52.91)	0.163	0.184
55	-	95 (3.438)	40 (1.563)	90 (3.25)	110 (4.344)	110 (4.344)	240 (9.438)	130 (5.125)	140 (5.5)	224 (8.813)	28 (1.094)	65 (2.563)	4 (0.156)	28 (1.094)	500 190	150 -90	-40	560 630	30 30	15	P	12	34 (74.96)	0.290	0.360
60	42 (1.656)	110 (4)	45 (1.75)	110 (4)	170 (6.688)	140 (5.5)	290 (11.406)	150 (5.906)	170 (6.688)	314 (12.375)	28 (1.094)	65 (2.563)	4 (0.156)	88 (3.469)	400 500	150 190	-	560 630 710	30 30 30	45	P	16	59 (130)	0.833	0.856
70	55 (2.156)	120 (4.5)	55 (2.156)	120 (4.5)	170 (6.688)	140 (5.5)	315 (12.403)	160 (6.313)	185 (7.281)	315 (12.406)	38 (1.5)	81 (3.188)	5 (0.188)	62 (2.438)	500	190	-20	630 710	30 30	29	R	16	79 (174.2)	1.400	1.430
80	65 (2.563)	135 (4.938)	65 (2.563)	130 (4.625)	210 (8.281)	210 (8.281)	354 (13.938)	178 (7)	200 (7.875)	425 (16.719)	38 (1.5)	100 (3.938)	5 (0.188)	90 (3.531)	500 630	190 236	58 30	710 795 1000	30 30 30	80	T	16	120.1 (264.8)	2.589	2.540
90	75 (2.938)	150 (5.5)	75 (2.938)	140 (5.188)	210 (8.281)	210 (8.281)	395 (15.563)	205 (8.063)	220 (8.656)	426 (16.781)	51 (2)	122 (4.813)	6 (0.25)	56 (2.219)	630 710	236 265	8	1000	30	58	I	12	157 (346.1)	4.711	4.450
95	85 (3.344)	180 (6.5)	90 (3.531)	155 (5.625)	210 (8.281)	210 (8.281)	460 (18.126)	250 (9.844)	260 (10.25)	426 (16.781)	56 (2.219)	122 (4.813)	6 (0.25)	51 (2)	630 710	236 265	-	1000	30	58	I	16	245 (540.1)	8.392	8.020

- Metric max bore with a keyway ISO 773 - DIN 6885/1
(Inch max bore with a keyway USAS B17.1 square)
- H tolerance: +1/-0.5 mm (+0.04/-0.02 inch)
- PD² (1kgm²) = Wk² (7.233 lbs-ft²)

Dimensions are subject to alteration without notice

BM-BMB-BMBP

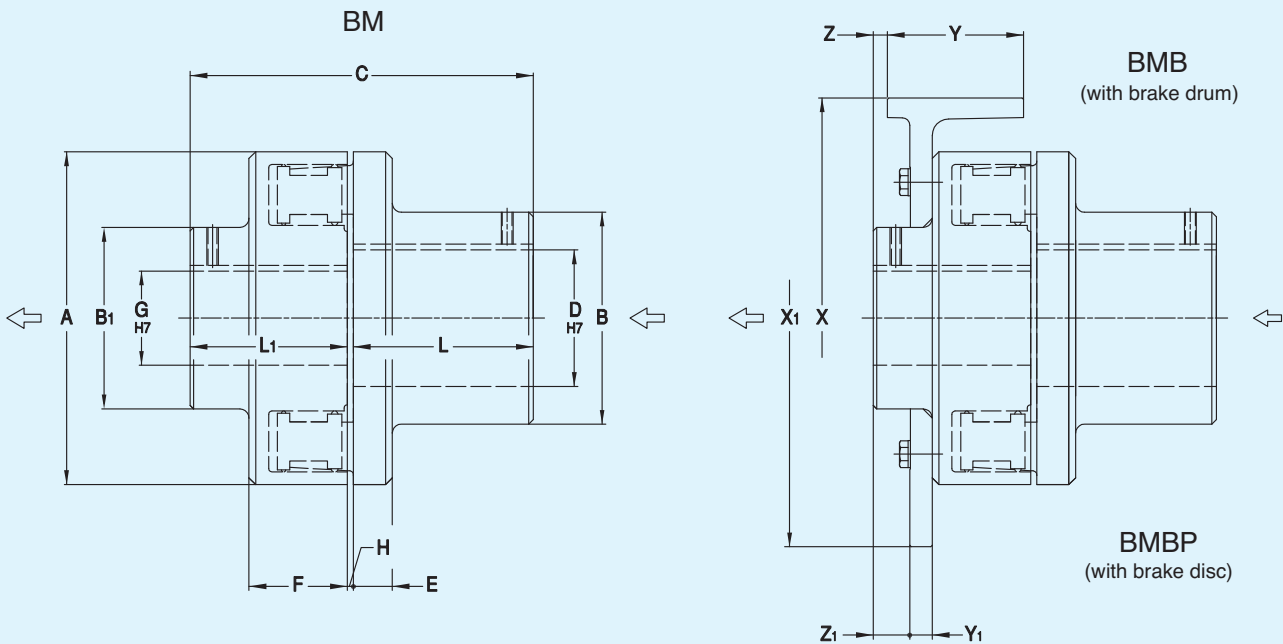

Tab. 8 Dimensions (mm)

Size	D		G		L	L1	A	B	B1	C	E	F	H	Brake Drum mm		Z	Brake Disc mm		Z1	Rubber Element		Weight	INPUT	OUTPUT
	mm	mm	mm	mm	mm	mm	mm	mm	mm	mm	mm	mm	mm	X	Y		X1	Y1		Type	Nr.	kg	PD ²	PD ²
	(inch)	(inch)	(inch)	(inch)	(inch)	(inch)	(inch)	(inch)	(inch)	(inch)	(inch)	(inch)	(inch)									(lbs)	(kgm ²)	(kgm ²)
01	-	19	-	19	35	35	62	35	35	72	8	25	2	-	-	-	-	-	-	A	8	0.8	0.007	0.007
	-	(0.75)	-	(0.75)	(1.375)	(1.375)	(2.438)	(1.375)	(1.375)	(2.844)	(0.313)	(0.969)	(0.094)									(1.76)		
02	-	28	-	25	40	40	73	45	45	82	9	27	2	On request	-	-	On request	-	-	A	8	1.4	0.011	0.004
	-	(1.125)	-	(1)	(1.563)	(1.563)	(2.875)	(1.781)	(1.781)	(3.219)	(0.344)	(1.063)	(0.094)									(3.86)		
05	-	32	-	32	50	50	86	55	55	102	11	30	2	On request	-	-	On request	-	-	B	8	2.3	0.023	0.027
	-	(1.25)	-	(1.25)	(1.969)	(1.969)	(3.375)	(2.156)	(2.156)	(4.031)	(0.438)	(1.188)	(0.094)									(5.07)		
10	-	42	-	42	60	60	110	70	70	122	11	33	2	160	60	-	On request	-	-	B	12	4.3	0.081	0.009
	-	(1.656)	-	(1.656)	(2.375)	(2.375)	(4.344)	(2.75)	(2.75)	(4.813)	(0.438)	(1.313)	(0.094)	200	75	-15						(9.5)		
20	-	60	-	55	110	80	132	90	85	192	13	42	2	200	75	5	On request	-	-	C	12	10.1	0.021	0.023
	-	(2.25)	-	(2.063)	(4.344)	(3.156)	(5.188)	(3.531)	(3.344)	(7.563)	(0.5)	(1.656)	(0.094)	250	95	-15						(22.26)		
40	-	80	-	80	110	110	170	120	120	223	25	45	3	250	95	15	395	30	35	C	16	22	0.082	0.064
	-	(3)	-	(3)	(4.344)	(4.344)	(6.688)	(4.719)	(4.719)	(8.781)	(0.969)	(1.781)	(0.125)	315	118	-8	450	30				(48.5)		
45	40	70	-	65	110	80	175	110	100	193	17	42	3	250	95	-	400	30	7	S	16	17	0.079	0.076
	(1.563)	(2.625)	-	(2.375)	(4.344)	(3.156)	(6.875)	(4.344)	(3.938)	(7.594)	(0.656)	(1.656)	(0.125)	315	118	-	450	30				(37.5)		
48	40	80	35	70	110	80	185	120	110	193	22	52	3	250	95	15	400	30	-2	N	12	19	0.117	0.114
	(1.563)	(3)	(1.375)	(2.625)	(4.344)	(3.156)	(7.281)	(4.719)	(4.344)	(7.594)	(0.875)	(2.063)	(0.125)	315	118	-	450	30				(41.9)		
50	35	90	35	90	170	110	250	140	135	283	30	65	3	315	118	-8	400	30	15	D	16	34	0.182	0.470
	(1.375)	(3.25)	(1.375)	(3.25)	(6.69)	(4.344)	(9.844)	(5.5)	(5.313)	(11.156)	(1.188)	(2.563)	(0.125)	400	150	-40	450	30				(74.9)		
55	45	90	40	90	140	110	240	150	140	254	27	65	4	400	150	-40	560	30	15	P	12	38	0.290	0.360
	(1.75)	(3.25)	(1.563)	(3.25)	(5.51)	(4.344)	(9.438)	(5.906)	(5.5)	(10)	(1.063)	(2.563)	(0.156)	500	190	-90	630	30				(83.8)		
60	65	110	45	110	170	140	290	170	170	314	27	65	4	400	150	-	560	30	45	P	16	60	0.790	0.856
	(2.563)	(4)	(1.75)	(4)	(6.688)	(5.5)	(11.406)	(6.688)	(6.688)	(12.375)	(1.063)	(2.563)	(0.156)	500	190	-50	630	30				(132.2)		
70	75	120	55	120	170	140	315	185	185	315	33	81	5	500	190	-20	630	30	29	R	16	80	1.310	1.430
	(2.938)	(4.5)	(2.156)	(4.5)	(6.688)	(5.5)	(12.406)	(7.281)	(7.281)	(12.406)	(1.313)	(3.188)	(0.188)				710	30				(176.2)		
80	85	130	65	130	210	210	354	200	200	425	36	100	5	500	190	58	710	30	80	T	16	108	2.480	2.540
	(3.344)	(4.625)	(2.563)	(4.625)	(8.281)	(8.281)	(13.938)	(7.875)	(7.875)	(16.719)	(1.406)	(3.938)	(0.188)	630	236	82	795	30				(238.1)		
90	85	140	75	140	210	210	395	220	220	426	51	122	6	630	236	60	1000	30	58	I	12	171	4.777	4.777
	(3.344)	(5.188)	(2.938)	(5.188)	(8.281)	(8.281)	(15.563)	(8.656)	(8.656)	(16.781)	(2)	(4.813)	(0.250)	710	265	-						(377)		

- Metric max bore with a keyway ISO 773 - DIN 6885/1
(Inch max bore with a keyway USAS B17.1 square)
- H tolerance: +1 /-0.5 mm (+0.04/-0.02 inch)
- PD² (1kgm²) = Wk² (7.233 lbs-ft²)

Dimensions are subject to alteration without notice

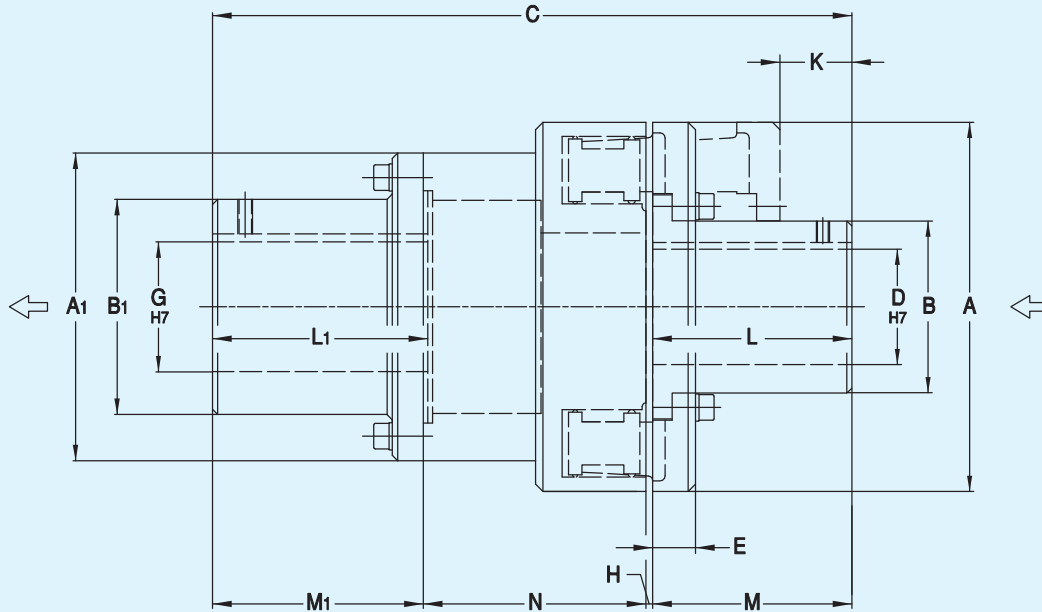

Tab. 9 Dimensions (mm)

Size 	D		G		L	L1	A	A1	B	B1	C	E	H	K	M	M1	N	Rubber Element		Weight kg (lbs)	INPUT PD ² ••• (kgm ²)	OUTPUT PD ² ••• (kgm ²)
	mm (inch) Min	mm (inch) Max *	mm (inch) Min	mm (inch) Max *														Type	Nr.			
	20	-	48 (1.781)	-	45 (1.75)	110 (4.344)	80 (3.156)	132 (5.188)	110 (4.344)	64 (2.531)	75 (2.938)	331 (13.031)	17 (0.656)	3 (0.125)	64 (2.531)	110 (4.344)	78 (3.063)	140 (5.5)	C	12	16 (35)	0.022
43	-	50 (1.938)	-	48 (1.781)	110 (4.344)	110 (4.344)	150 (5.906)	120 (4.719)	70 (2.750)	82 (3.219)	361 (14.219)	17 (0.656)	4 (0.156)	59 (2.313)	110 (4.344)	107 (4.219)	140 (5.5)	S	12	22 (48.5)	0.028	0.103
45	-	60 (2.25)	-	65 (2.375)	110 (4.344)	110 (4.344)	175 (6.875)	145 (5.719)	80 (3.156)	100 (3.938)	361 (14.219)	20 (0.781)	4 (0.156)	60 (2.375)	110 (4.344)	107 (4.219)	140 (5.5)	S	16	27.5 (60.6)	0.074	0.208
48	-	75 (2.75)	35 (1.375)	70 (2.625)	110 (4.344)	110 (4.344)	185 (7.281)	155 (6.094)	100 (3.938)	110 (4.344)	401 (15.781)	23 (0.906)	4 (0.156)	42 (1.656)	110 (4.344)	107 (4.219)	180 (7.094)	N	12	32 (70.5)	0.116	0.290
53	-	80 (3)	35 (1.375)	80 (3)	110 (4.344)	110 (4.344)	200 (7.875)	170 (6.688)	110 (4.344)	125 (4.906)	421 (16.563)	28 (1.094)	4 (0.156)	28 (1.094)	110 (4.344)	107 (4.219)	200 (7.875)	E	12	41 (90.4)	0.163	0.421
55	-	95 (3.438)	40 (1.563)	90 (3.25)	110 (4.344)	140 (5.5)	240 (9.438)	200 (7.875)	130 (5.125)	140 (5.5)	451 (17.75)	28 (1.094)	5 (0.188)	28 (1.094)	110 (4.344)	137 (5.406)	200 (7.875)	P	12	56 (123.5)	0.290	1.053

- Metric max bore with a keyway ISO 773 - DIN 6885/1
(Inch max bore with a keyway USAS B17.1 square)
- H tolerance: +1/-0.5 mm (+0.04/-0.02 inch)
- PD² (1kgm²) = Wk² (7.233 lbs-ft²)

Dimensions are subject to alteration without notice

SHAFT MISALIGNMENT

Flexible couplings **BM** series can withstand radial, axial, angular misalignment values according to Tab. 10; such values are just approximate values because the coupling compensation capability depends on applied load and rotational speed values. It is recommended anyway to perform the best possible alignment during installation.

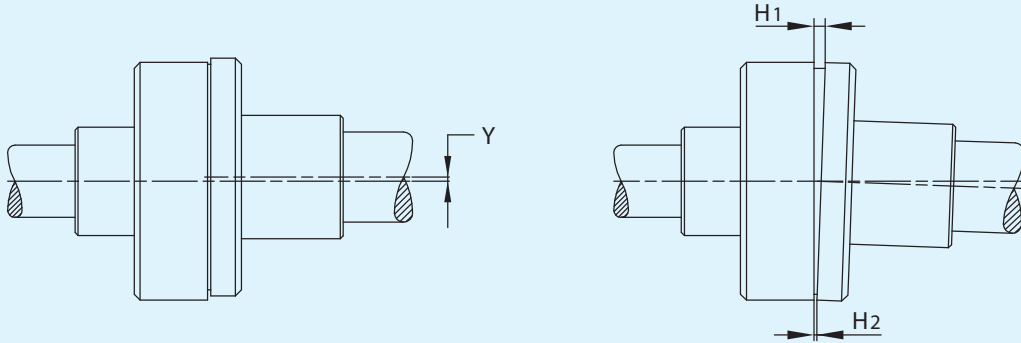

Tab. 10

Size		Max shaft misalignment (up to 1800 rpm)																
		01	02	05	10	20	40	43	45	48	50	53	55	60	70	80	90	95
Y	mm	0.2	0.2	0.2	0.3	0.35	0.4	0.35	0.35	0.35	0.5	0.35	0.41	0.45	0.50	0.60	0.80	1
	(inch)	(0.008)	(0.008)	(0.008)	(0.012)	(0.014)	(0.016)	(0.014)	(0.014)	(0.014)	(0.020)	(0.014)	(0.016)	(0.018)	(0.020)	(0.024)	(0.031)	(0.039)
*H _{nominal}	B3M/BM mm	2	2	2	2	2	3	3	3	3	3	3	4	4	5	5	6	6
	(inch)	(0.08)	(0.08)	(0.08)	(0.08)	(0.08)	(0.12)	(0.12)	(0.12)	(0.12)	(0.12)	(0.12)	(0.16)	(0.16)	(0.20)	(0.20)	(0.24)	(0.24)
BMS	mm	-	-	-	-	3	-	4	4	4	-	4	5	-	-	-	-	-
	(inch)	-	-	-	-	(0.12)	-	(0.16)	(0.16)	(0.16)	-	(0.16)	(0.20)	-	-	-	-	-
H ₁ -H ₂	mm	1.1	1.3	1.5	1.7	1.9	2.2	1.9	2.3	1.9	2.5	2	2.4	2	1.8	1.5	1.4	1.4
	(inch)	(0.043)	(0.051)	(0.059)	(0.067)	(0.075)	(0.086)	(0.075)	(0.090)	(0.075)	(0.098)	(0.08)	(0.094)	(0.08)	(0.071)	(0.059)	(0.055)	(0.055)

*H nominal tolerance: + 1 /-0.5 mm (+0.04 / -0.02 inch)

For operating rotational speed **higher than 1800 rpm**, it is recommended to reduce by 50% the max allowable misalignment.

Maximum rotational speed cannot exceed the allowable values indicated at Tab. 1 pag. 3.

BALANCING

All couplings are balanced according to ISO 1940 G16 as a standard which is suitable for normal speed range. Higher balancing quality according to G6.3 is available upon request.

MAINTENANCE

Replace rubber elements when total thickness is lower than 90%

of its nominal dimension. (see dimension data on Tab. 14).

ATTENTION: the rubber elements must never get in contact with paint thinner, petrol or other chemicals.

SAFETY

The couplings must be installed complete with proper protection guards in order to provide complete safety for personnel during operation.

The installer and the end user are responsible to assure adequate protection of the rotating parts and to comply to the required standards of the country where the equipment is installed.

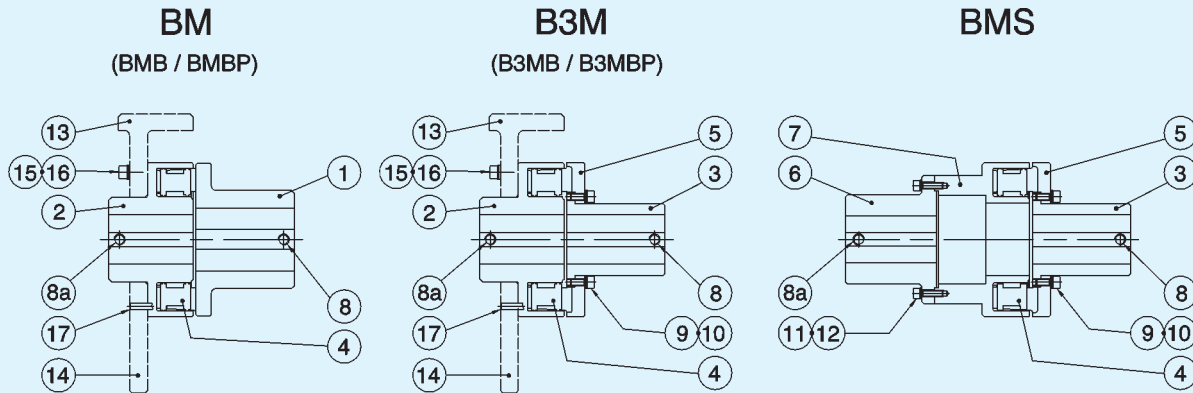

Tab. 11

Pos.	Name	Material
• 1	MALE HUB	Cast Iron EN-GJL-250
• 2	FEMALE	
3	HUB	Nodular Iron EN-GJS-400 or Steel Fe 510
•• 4	RUBBER ELEMENT	Special mix 70°Sh(A) ±5 [-40°C (-40°F); +120°C (+248°F)]
• 5	MALE	Cast Iron EN-GJL-250
• 6	FLANGE	Cast Iron EN-GJL-250 or Steel Fe 510
• 7	SPACER	Cast Iron EN-GJL-250
8-8a	SET SCREW (metric)	Steel 12.9

Pos.	Name	Material
9	SCREW (metric)	Steel 12.9
10	LOCK WASHER	Steel SS 2343
11	SCREW (metric)	Steel 12.9
12	LOCK WASHER	Steel SS 2343
• 13	BRAKE DRUM	Cast iron EN-GJL-250 or Steel Fe 510
• 14	BRAKE DISC	
15	SCREW (metric)	Steel 8.8
16	LOCK WASHER	Steel SS 2343
17	DOWEL PIN	Steel C72 (elastic) or Steel hardened HRC 60±2 (parallel)

- On request special nodular Iron EN-GJS-350-22 LT for low temperature -40°C (-40°F)
- On request special rubber 60°Sh(A) or 80°Sh(A)

Tab. 12 - Screw tightening torque

Pos.	Size	01		02		05		10		20		40		43		45		48		50		53		55		60		70		80		90		95	
		SCREW	Nm	SCREW	Nm	SCREW	Nm	SCREW	Nm	SCREW	Nm	SCREW	Nm	SCREW	Nm	SCREW	Nm	SCREW	Nm	SCREW	Nm	SCREW	Nm	SCREW	Nm	SCREW	Nm	SCREW	Nm	SCREW	Nm	SCREW	Nm		
9		-	-	-	-	-	-	-	-	M6	18	-	-	M6	18	M8	42	M10	85	-	-	M12	143	M14	228	M10	85	M12	143	M14	228	M24	1170	M24	1170
11		-	-	-	-	-	-	-	-	M8	42	-	-	M10	85	M10	85	M10	85	-	-	M10	85	M12	143	-	-	-	-	-	-	-	-	-	
8-8a	For max bore set screw should be placed at 90° from keyway - for type and dimensions see table TF5726																																		
15	Tightening torque according to screw size and class, please refer to table N 1152																																		
17	For dowel pin dimensions contact TRANSFLUID																																		

Tab. 13 - Rubber element type and quantity

01		02		05		10		20		40		43		45		48		50		53		55		60		70		80		90		95	
TYPE	Nr.	TYPE	Nr.	TYPE	Nr.	TYPE	Nr.	TYPE	Nr.	TYPE	Nr.	TYPE	Nr.	TYPE	Nr.	TYPE	Nr.	TYPE	Nr.	TYPE	Nr.	TYPE	Nr.	TYPE	Nr.	TYPE	Nr.	TYPE	Nr.	TYPE	Nr.	TYPE	Nr.
A	8	A	8	B	8	B	12	C	12	C	16	S	12	S	16	N	12	D	16	E	12	P	12	P	16	R	16	T	16	I	12	I	16

Tab. 14 - Rubber element dimensions

↔ Type

Dimensions (mm)	A		B		C		D		E		I		N		P		R		S		T	
	mm	(inch)	mm	(inch)	mm	(inch)	mm	(inch)	mm	(inch)	mm	(inch)	mm	(inch)	mm	(inch)	mm	(inch)	mm	(inch)	mm	(inch)
a	6.7 (0.264)	7 (0.275)	10.9 (0.429)	16 (0.630)	19.6 (0.772)	35 (1.378)	14.7 (0.579)	19.7 (0.775)	20.5 (0.807)	11.8 (0.464)	23.9 (0.941)											
b	10 (0.394)	13.5 (0.531)	17 (0.669)	22 (0.866)	30 (1.181)	68 (2.677)	29 (1.142)	40 (1.575)	40 (1.575)	19.5 (0.768)	49 (1.929)											
c	14.5 (0.571)	18.25 (0.719)	25 (0.984)	39 (1.535)	50 (1.968)	98 (3.858)	39 (1.535)	49 (1.929)	64 (2.520)	30 (1.181)	74 (2.913)											

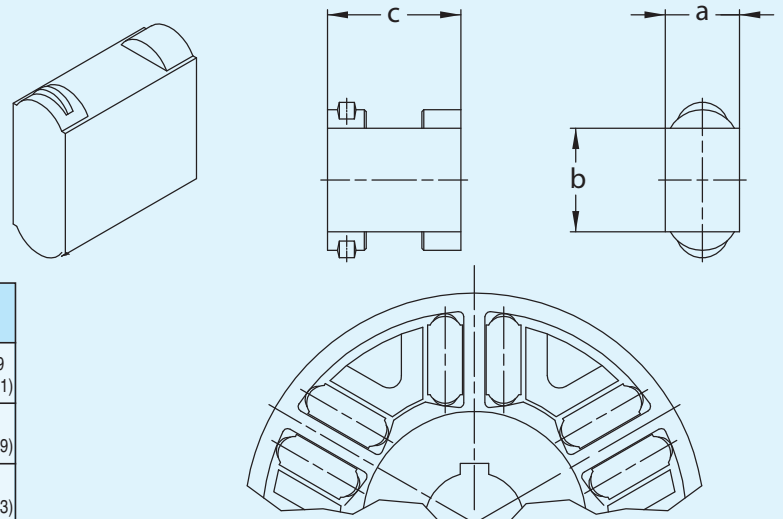

Dimensions are subject to alteration without notice

FLUID COUPLING
K series

Constant filling
up to 2500 kW

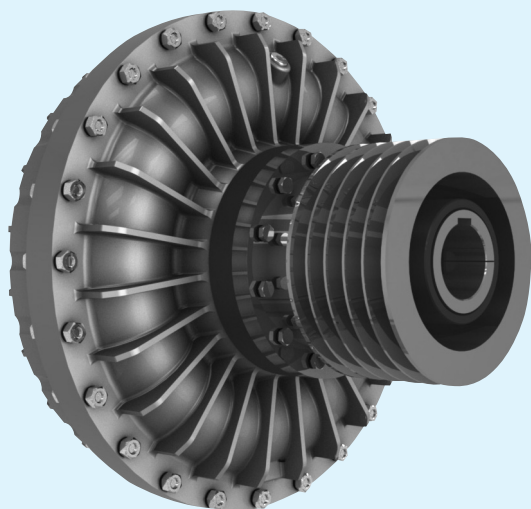

FLUID COUPLING
KX series

Constant filling
up to 1000 kW



DISC AND DRUM BRAKE
TFDS-NBG series

up to 19000 Nm

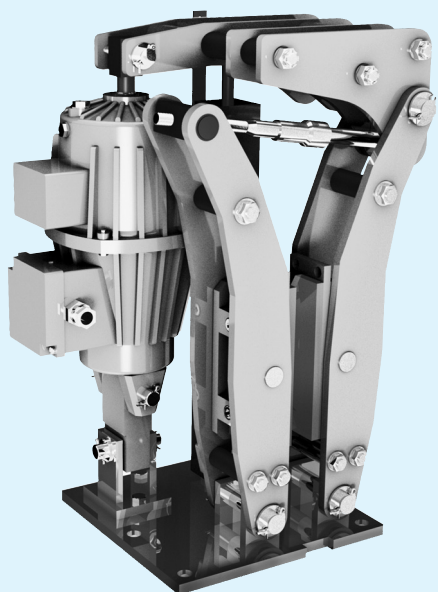

PNEUMATIC CLUTCH
TP series

up to 11500 Nm

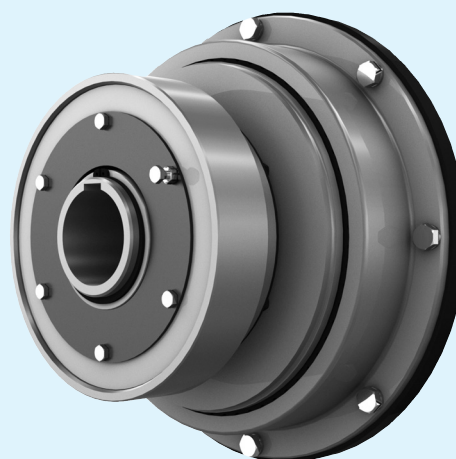

AUSTRALIA

TRANSLUID AUSTRALIA PTY LTD
Smithfield NSW 2164
Tel. +61 297572655
Fax +61 297560181
tfaustralia@transfluid.it

BRAZIL

TRANSLUID DO BRASIL
Representative Office
05014-060 Sao Paulo SP
Tel.: +55.11.48235308
Fax: +55.11.48235308
tbrasil@transfluid.it

CHINA

TRANSLUID BEIJING TRADE CO. LTD
Beijing
Tel.: +86.60442301-2
Fax: +86.60442305
tbtinfo@sina.com

FRANCE

TRANSLUID FRANCE s.a.r.l.
38110 Rochetoirin
Tel.: +33.9.75635310
Fax: +33.4.26007959
tfrance@transfluid.it

RUSSIAN FEDERATION

TRANSLUID OOO
Moscow
Tel. +7.495.7782042
Mob.: +7.926.8167357
trussia@transfluid.it

U.S.A. & CANADA

TRANSLUID LLC
Auburn, GA 30011
Tel.: +1.770-822-1777
Fax: +1.770-822-1774
tfusa@transfluid.it

Global web site: www.transfluid.eu • E-commerce web site: www.buy-transfluid.com

TRANSLUID s.r.l. • Via Guido Rossa, 4 • 21013 Gallarate (VA) Italy • Tel. +39 0331 28421 • Fax +39 0331 2842911 • info@transfluid.it
1403 - 250 GB